

## Motor load monitor BA 9067 varimeter

0225111



- According to IEC 255, EN 60 255, VDE 0435 Teil 303
- Detection of
  - underload
  - overload
- Measures effective power
- 1 changeover contact for underload, 1 changeover contact for overload
- Adjustable start-up delay  $t_a$
- Adjustable operate delay
- Open or closed circuit operation
- Without neutral
- Optionally with neutral
- Width 45 mm

### Function diagram

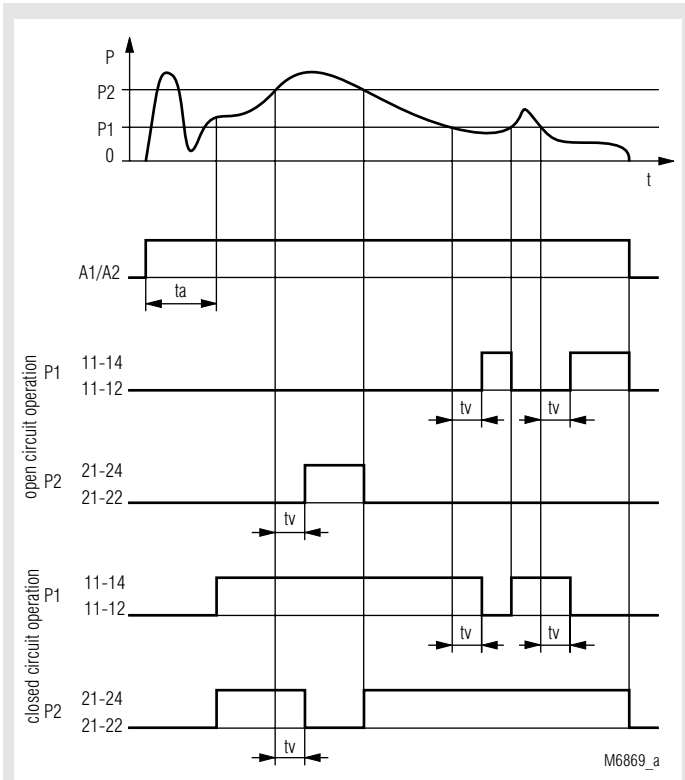

### Approvals and marking



### Applications

The BA 9067 is used to monitor variable loads on industrial motors

### Function

The BA 9067 monitors the effective power consumption  $p = U \times I \times \cos \varphi$  of electrical consumers. With 2 potentiometers the underload and the overload value can be set. Under- and overload is indicated by 2 yellow LEDs as long as the motor is running on under- or overload. When the motor is switched the LEDs turn off because the BA 9067 is also disconnected. After an operate delay an output relay is activated. In addition the unit includes a start-up delay and a green LED to show operational state. The BA 9067.38 is for single phase or 3 phase 4 wire systems and the BA 9067.38/001 for 3 phase 4 wire systems.

On DIP switches settable:

- Input current range up to 1, 2, 3, 4, 5 A or up to 2, 4, 6, 8, 10 A
- closed or open circuit operation

### Connection

The connection has to be made according to the connection diagrams. To feed in the motor current the terminals i and k have to be used keeping in mind the direction of the current. The terminal i is wired to the supply side and the terminal k to the motor side. The max. current over these terminals is 5 resp. 10 A. For higher values a current transformer must be used.

### Connection details

If the measurement is still incorrect the connections i and k must be exchanged against each other.

### Circuit diagrams

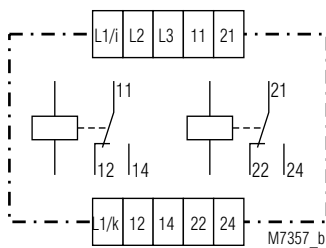

BA 9067.38/001

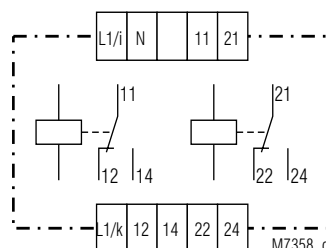

BA 9067.38

## Technical data

### Input

#### Nominal voltage $U_N$ , L1/N:

BA 9067.38: AC 230, 400 V

#### Nominal voltage $U_N$ , L1/L2/L3:

BA 9067.38/001: 3 AC 230, 400, 690 V  
Application class: II  
Voltage range: 0,8 ... 1,05  $U_N$

#### Voltage range:

0,8 ... 1,1  $U_N$

#### Frequency range of $U_N$ :

50 / 60 Hz

#### Nominal consumption:

2 VA

#### Nominal current:

1 ... 5 A (Terminals i-k), or 2 ... 10 A

#### Max. overload:

16 A, 3 s

### Setting ranges

P1: 1 ... 10 on relative scale

P2: 1 ... 10 on relative scale

#### Setting accuracy:

± 3 % of max. value

#### Operate delay $t_v$ :

0,1 ... 1 s 1 ... 10 s

#### Start-up delay $t_a$ :

0,3 ... 3 s 1 ... 30 s

### Output

#### Contacts

BA 9067.38: 1 changeover contact for  $P_1$   
1 changeover contact for  $P_2$

#### Release delay:

≤ 50 ms

#### Thermal current $I_{th}$ :

5 A

#### Switching capacity

to AC 15

NO contact: 3 A / AC 230 V EN 60 947-5-1

NC contact: 1 A / AC 230 V EN 60 947-5-1

Electrical life: EN 60 947-5-1

to AC 15 at 3 A, AC 230 V: 2 x 10<sup>5</sup> switching cycles

#### Permissible switching

frequency: 1800 switching cycles / h

#### Short circuit strength

max. fuse rating: 4 A gL EN 60 947-5-1

#### Mechanical life:

30 x 10<sup>6</sup> switching cycles

### General data

Operating mode: Continuous operation

Temperature range: - 20 ... + 60 °C

#### Clearance and creepage distances

overvoltage category /  
contamination level: 4 kV / 2 IEC 60 664-1

#### EMC

Electrostatic discharge: 8 kV (air) EN 61 000-4-2

HF irradiation: 10 V / m EN 61 000-4-3

Fast transients: 2 kV EN 61 000-4-4

#### Surge voltages

between

wires for power supply: 1 kV EN 61 000-4-5

between wire and ground: 2 kV EN 61 000-4-5

HF-wire guided: 10 V EN 61 000-4-6

Interference suppression: Limit value class B EN 55 011

Degree of protection: Housing: IP 40 EN 60 529

Terminals: IP 20 EN 60 529

Housing: Thermoplastic with V0 behaviour

according to UL subject 94

#### Vibration resistance:

Amplitude 0,35 mm  
frequency 10 ... 55 Hz EN 60 068-2-6

Climate resistance: 20 / 060 / 04 EN 60 068-1

#### Terminal designation:

2 x 2,5 mm<sup>2</sup> solid or

2 x 1,5 mm<sup>2</sup> stranded wire with sleeve

DIN 46 228/-1/-2/-3/-4

#### Wire fixing:

Flat terminals with self-lifting

clamping piece EN 60 999

#### Mounting:

DIN rail EN 50 022

#### Weight:

360 g

### Dimensions

Width x height x depth: 45 x 74 x 131 mm

## Standard type

BA 9067.38/001 3 AC 400 V 50/60 Hz 5 A

Article number: 0041104 stock item

• Without neutral

• Output: 1 changeover contact for underload,  
1 changeover contact for overload

• Nominal voltage  $U_N$ : 3 AC 400 V

• Nominal current: 5 A

• Width: 45 mm

## Variants

BA 9067.38: with neutral  
3 AC 230, 400 V

BA 9067.38/020: detects overload on 2 independent  
seetable overload values, open circuit  
operation

BA 9067.38/030: same as BA9067.38/020, but closed  
circuit operation

## Ordering example for variants

BA 9067.38 / \_ \_ \_ 3 AC 400 V 50/60Hz 30 s 10 s 5 A

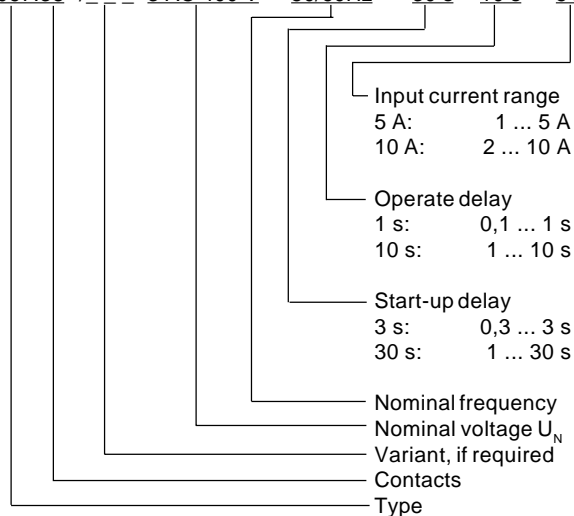

## Connection examples

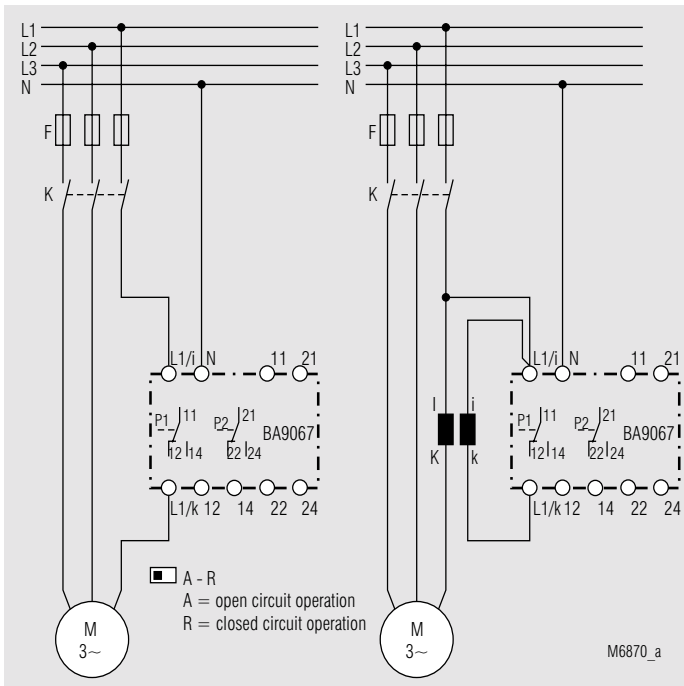

BA 9067.38  
for current < 10 A

BA 9067.38  
for current > 10 A with CT

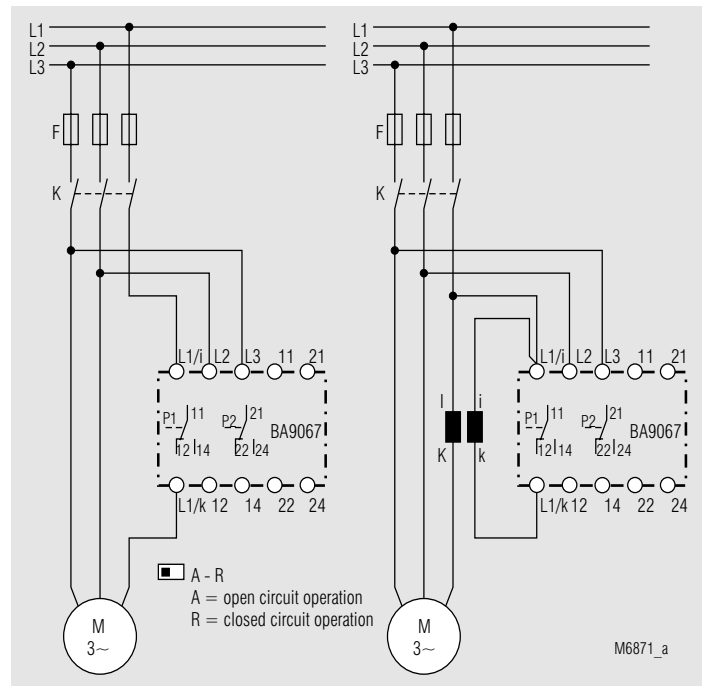

BA 9067.38/001  
for current < 10 A

BA 9067.38/001  
for current > 10 A with CT

## Set-up procedure

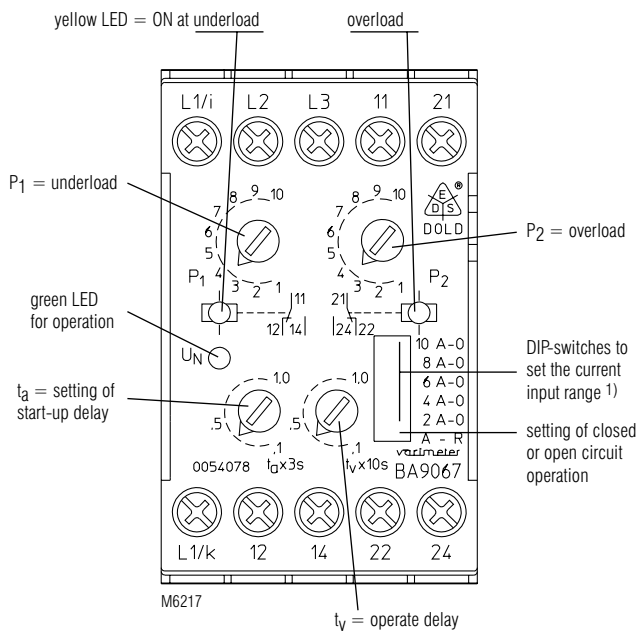

**1) Attention:** The required measuring range must be selected by putting the relevant DIP-switch to left position. All other range selector DIP-switches are in right position.

Before setting up the unit we recommend to evaluate the current expected to flow in order to preset the current range with the DIP-switches.

**Example:** Motor 55 kW  
Nominal current 100 A  
Current transformer to be used 100/5  
DIP-switch to be set to position 5 A

## Variant 1:

This method is recommended when the different load situations of the motor cannot be achieved during set-up.

- 1.) Calibration of the device according to the following equation:

$$P_{\max} = \sqrt{3} \times U_N \times I \times \ddot{u}$$

$P_{\max}$  = effective power measured by the device at max. scale value (pot in pos. 10)

$U_N$  = Nominal voltage of the three phase system (e.g. 400 V)

$I$  = current selected on DIP-switches (e.g. 5 A)

$\ddot{u}$  = transformation ratio of CT, if connected (e.g. 100/5 = 20)

Result:  $P_{\max} = 69,3 \text{ kW}$

- 2.) Evaluate the efficiency factor of the motor at the required load situations from tables.

e.g.

$\eta \approx 0,9 \dots 0,93$  depending on load for motors from 11 ... 55 kW

$\eta \approx 0,7 \dots 0,87$  depending on load for motors from 0,55 ... 7,5 kW

- 3.) Calculation of the effective power  $P$  using the mechanical output load  $P_{\text{mech}}$  and the efficiency factor  $\eta$  at a certain load situation.

$$P = P_{\text{mech}} / \eta$$

e.g. at partial load  $P_{\text{mech}} = 30 \text{ kW}$

Result  $P = 33 \text{ kW}$

- 4.) Setting of the upper response value (pot P2) and the lower response value (pot P1) on scale.

$$\text{Scale value} = 10 \times P / P_{\max} = 10 \times 33 / 69,3 \approx 5$$

I. e. the potentiometer must be set to 5, that the device trips at 30 kW motor load. Setting tolerances may lead to slightly different values.

- 5.) Do the same procedure for the 2.) response value

- 6.) Set the unit to the required functions:  
closed or open circuit operation  
start-up delay  
operate delay

**Variant 2**

This method is recommended when it is possible to simulate the different load situations during set-up. In this case nothing has to be calculated. Turn the operate delay to min. The motor runs in underload while the Pot 1 is turned until the output relay switches. The same has to be done for overload. Now the unit is set accurately. Now adjust the operate delay and the start-up delay to the required values.

**Variant 3**

This method is the most simple one but not the most accurate. The operate delay is set to min. The motor is switched on and runs on nominal load. With both potentiometers the set points are searched by slowly turning the max. Pot from high to low value and the min. Pot from low to high value until the corresponding output relays switch. After that turn the Pot P2 slightly to the right side and the Pot 1 slightly to the left until the output relays reset. The unit is now set and responds if the load differs from the nominal value. Finally set the operate delay and start up delay to the required values.