

Monitoring technique

Current relay BA 9053, MK 9053 varimeter

Now available with new features



- According to IEC 255, EN 60 255, VDE 0435 part 303
- to: monitor DC and AC
- Measuring ranges from 2 mA to **25 A**
- BA 9053 optionally with 3 current ranges 0,1 to **25 A**
- BA 9053 optionally with safe separation to VDE 0106 part 101
- BA 9053 with galvanic separated DC auxiliary supply
- MK 9053 optionally with remote potentiometer
- High overload possible
- **Input frequency up to 5 kHz**
- with time delay, up to max. 100 sec
- **BA 9053 as option with start-up delay**
- **BA 9053 as option with manual reset**
- LED indicators for operation and contact position
- Width MK 9053: 22,5 mm
- Width BA 9053: 45 mm

Circuit diagrams

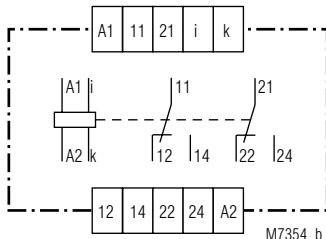

BA 9053

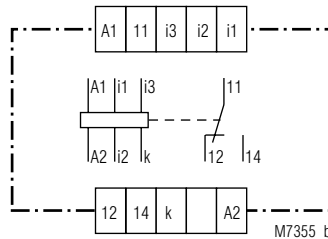

BA 9053/4_ _

- e.g.:
- Terminals i1/k: 0,1 ... 1 A
 - Terminals i2/k: 0,5 ... 5 A
 - Terminals i3/k: 1 ... 10 A

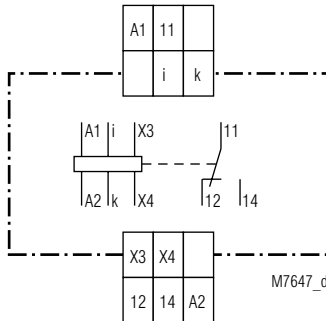

MK 9053

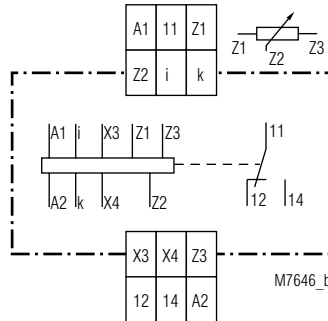

MK 9053/1_ _

Approvals and marking



* see Variants

Applications

Monitoring current in AC or DC systems

Function

The relays measure the arithmetic mean value of the rectified measuring current. The AC units are adjusted to the r.m.s value. They have settings for response value and hysteresis. The units work as overcurrent relays but can also be used for undercurrent detection. The hysteresis is dependent on the response value. The BA 9053 is optionally available with time delay. On the MK 9053 a fixed time delay can be activated by linking terminals X3-X4.

Indicators

- green upper LED: on, when auxiliary supply connected
- yellow lower LED: on, when output relay activated

Function diagram without start-up delay

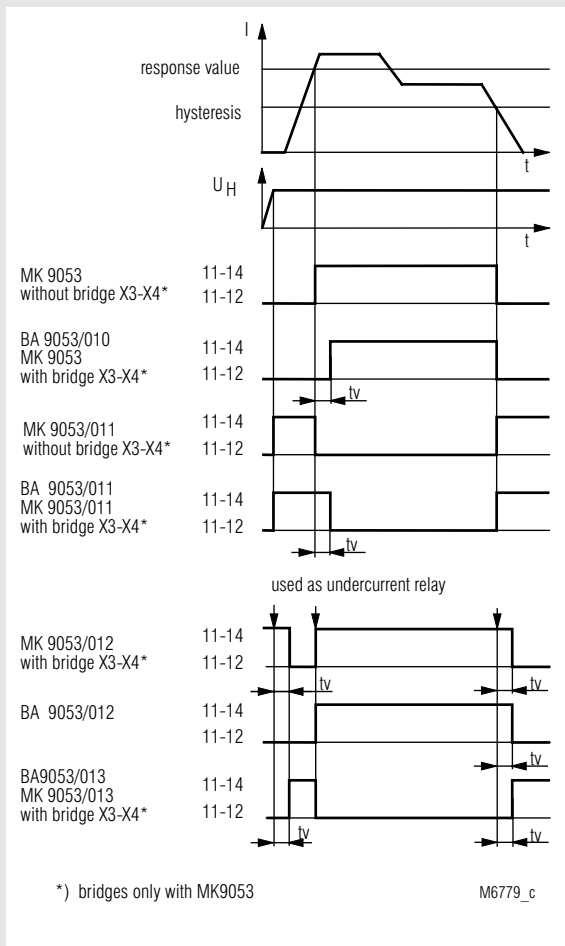

Function diagram with start-up delay

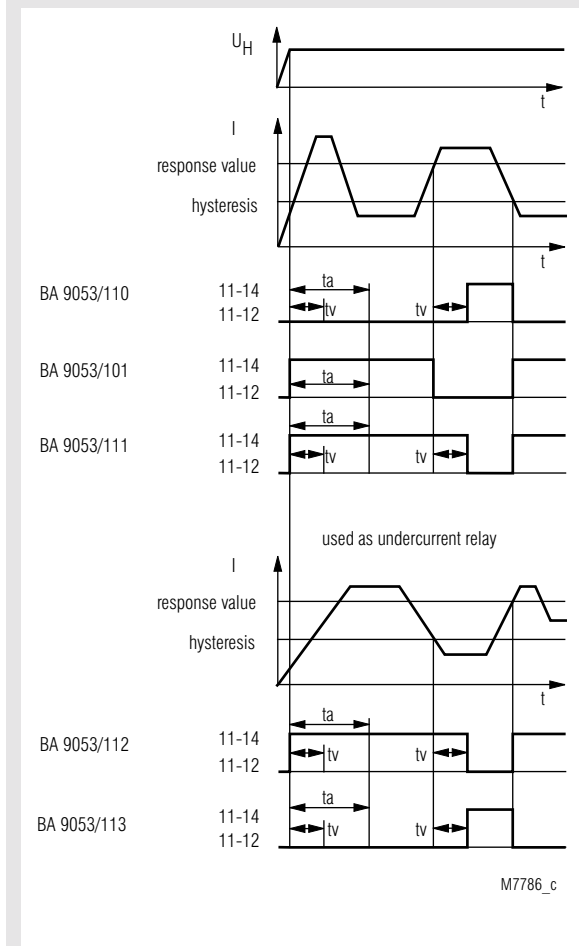

On model BA 9053/6_ _ with manual reset the contacts remain in the fault state after detecting a fault or after to has elapsed. The contacts

are reset by disconnecting the supply voltage.

Technical data

Input

BA 9053 with 1 Measuring range for AC and DC				
Measuring range*		internal resistance	max. permiss. continuous current	max. permiss. current for 3 s on, 100 s off
AC	DC			
2 - 20 mA	1,8 - 18 mA	1,5 Ω	0,7 A	1 A
20 - 200 mA	18 - 180 mA	0,15 Ω	2 A	4 A
30 - 300 mA	27 - 270 mA	0,1 Ω	2,5 A	8 A
50 - 500 mA	45 - 450 mA	0,1 Ω	2,5 A	8 A
80 - 800 mA	72 - 720 mA	40 mΩ	4 A	12 A
0,1 - 1 A	0,09 - 0,9 A	30 mΩ	5 A	15 A
0,5 - 5 A	0,45 - 4,5 A	6 mΩ	10 A	30 A
1 - 10 A	0,9 - 9 A	3 mΩ	20 A	40 A
1,5 - 15 A	1,35 - 13,5 A	3 mΩ	25 A	40 A
2 - 20 A	1,8 - 18 A	3 mΩ	25 A	40 A
2,5 - 25 A	2,25 - 22,5 A	3 mΩ	25 A	40 A

* DC or AC current 50 ... 5000 Hz (other frequency ranges of 10 ... 5000 Hz, e.g. 16 2/3 Hz, on request)

MK 9053 with 1 Measuring range				
Measuring* range AC or DC	internal resistance	max. permissible continuous current		max. permissible current 3 s
		devices mounted without distance	with 5 mm distance	
2 - 20 mA	1,5 Ω	0,5 A	0,7 A	1 A
20 - 200 mA	0,15 Ω	1,5 A	2 A	4 A
30 - 300 mA	0,1 Ω	2 A	2,5 A	8 A
50 - 500 mA	0,1 Ω	2 A	2,5 A	8 A
0,1 - 1 A	30 mΩ	3,5 A	5 A	10 A
0,5 - 5 A	6 mΩ	8 A	11 A	20 A
1 - 10 A	3 mΩ	12 A	15 A	20 A

*DC or AC current 50 ... 5000 Hz (to be ordered)

BA 9053/4_ _¹⁾:

	terminals i3/k	terminals i2/k	terminals i1/k
AC and DC	0,1 ... 1 A +	20 ... 200 mA +	2,0 ... 20 mA
AC and DC	0,09 ... 0,9 A +	18 ... 180 mA +	1,8 ... 18 mA
AC and DC	1,0 ... 10 A +	0,5 ... 5 A +	0,1 ... 1 A
AC and DC	0,9 ... 9 A +	0,45 ... 4,5 mA +	0,09 ... 0,9 mA
AC and DC	2,5 ... 25 A +	1,0 ... 10 A +	0,5 ... 5 A
AC and DC	2,25 ... 22,5 A +	0,9 ... 9 A +	0,45 ... 4,5 A

¹⁾ with 3 Measuring ranges

Extending of measuring range:

For DC-current higher then the highest measuring range the voltage relay BA9054 or MK9054 measuring range 15 ... 150 mV can be used together with secondary winding of 150 mV. The nominal load of the CT should be $\geq 2,5$ VA. arithmetic mean value

Measuring principle:

Technical data	
Adjustment:	The AC - devices can also monitor DC current. The scale offset in this case is: ($\bar{I} = 0,90 I_{eff}$)
Temperature influence:	< 0,05 % / K
Setting ranges	
Setting:	
Response value:	infinite variable $0,1 I_N \dots 1 I_N$ relative scale
Hysteresis:	infinite variable 0,5 ... 0,98 of setting value $\leq \pm 5 \%$
Accuracy:	
Time delay t_v	
BA 9053:	infinite variable at logarithmic scale from 0-20 s, 0-30 s, 0-60 s, 0-100 s setting 0 s = without time delay approx. 1 s or 5 s, fixed The units are delivered with a bridge between terminals X3 - X4. If this bridge is removed the time delay is inactive.
MK 9053:	
Start-up delay	
BA9053/1 __:	1 - 20 s; 1 - 60 s; 1 - 100 s, adjustable on logarithmic scale. t_s is started when the supply voltage is connected. During elapse of time the output contact is in good state.
Auxiliary circuit	
Auxiliary voltage U_H:	
BA 9053:	AC 24, 110, 127, 230, 400 V AC/DC 24 ... 60 V, AC/DC 110 ... 230 V
MK 9053:	AC 24, 42, 110, 127, 230 V
Voltage range:	0,8 ... 1,1 U_H
Nominal consumption:	
BA 9053:	approx. 2,5 VA
MK 9053:	approx. 2 VA
Nominal frequency:	50 / 60 Hz
Frequency range:	$\pm 5 \%$
Output	
Contacts	
BA 9053:	2 changeover contacts
MK 9053:	1 changeover contact
Thermal current I_{th}	
BA 9053:	2 x 5 A or 1 x 8 A
MK 9053:	5 A
Switching capacity	
to AC 15:	
NO contact:	3 A / AC 230 V EN 60 947-5-1
NC contact:	1 A / AC 230 V EN 60 947-5-1
Electrical life	
to AC 15 at 3 A, AC 230 V	EN 60 947-5-1
BA 9053:	5 x 10 ⁵ switching cycles
MK 9053:	10 ⁵ switching cycles
Short-circuit strength	
max. fuse rating:	6 AgL EN 60 947-5-1
Mechanical life	
BA 9053:	50 x 10 ⁶ switching cycles
MK 9053:	30 x 10 ⁶ switching cycles
General data	
Operating mode:	Continuous operation
Temperature range:	
BA 9053:	- 40 ... + 50°C
MK 9053:	- 20 ... + 50°C
Clearance and creepage distances	
overvoltage category / contamination level:	4 kV / 2 IEC 60 664-1

Technical data	
EMC	
Electrostatic discharge:	8 kV (air) EN 61 000-4-2
HF irradiation:	10 V/m EN 61 000-4-3
Fast transients:	4 kV EN 61 000-4-4
Surge voltages between wires for power supply:	2 kV EN 61 000-4-5
between wire and ground:	4 kV EN 61 000-4-5
Interference suppression:	Limit value class B EN 55 011
Degree of protection:	Housing: IP 40 EN 60 529
	Terminals: IP 20 EN 60 529
Housing:	Thermoplastic with V0 behaviour according to UL subject 94
Vibration resistance:	Amplitude 0,35 mm frequency 10 ... 55 Hz EN 60 068-2-6
Climate resistance	
BA 9053	
≤ 10 A:	20 / 060 / 04 EN 60 068-1
≥ 15 A:	20 / 050 / 04 EN 60 068-1
MK 9053:	20 / 060 / 04 EN 60 068-1
Terminal designation:	EN 50 005
Wire connection	
BA 9053:	2 x 2,5 mm ² solid or 2 x 1,5 mm ² stranded wire with sleeve DIN 46 228-1/-2/-3/-4
MK 9053:	2 x 1,5 mm ² solid or 2 x 1 mm ² stranded wire with sleeve DIN 46 228-1/-2/-3/-4
Wire fixing:	Flat terminals with self-lifting clamping piece EN 60 999 DIN rail EN 50 022
Mounting:	
Weight:	
BA 9053:	AC-devices: 280 g AC/DC-devices: 200 g
MK 9053:	160 g
Dimensions	
Width x height x depth	
BA 9053:	45 x 73 x 132 mm
MK 9053:	22,5 x 82 x 102 mm
Standard types	
BA 9053/010 AC 0,5 ... 5 A AC 230 V	
Article number:	0053128 stock item
• for Overcurrent monitoring	
• Measuring range:	AC 0,5 ... 5 A
• Auxiliary voltage U_H :	AC 230 V
• time delay by I_{an} :	0 ... 20 s
• Width:	45 mm
BA 9053/012 AC 0,5 ... 5 A AC230V	
Article number:	0053192 stock item
• for Undercurrent monitoring	
• Measuring range:	AC 0,5 ... 5 A
• Auxiliary voltage U_H :	AC 230 V
• time delay by I_{ab} :	0 ... 20 s
• Width:	45 mm
MK 9053 AC 0,5 ... 5 A AC 230 V 1 s	
Article number:	0026784 stock item
• for Overcurrent monitoring	
• Measuring range:	AC 0,5 ... 5 A
• Auxiliary voltage U_H :	AC 230 V
• Time delay by I_{an} :	1 s
• Width:	22,5 mm
MK 9053/012 AC 0,5 ... 5 A AC 230V 1 s	
Article number:	0027151 stock item
• for Undercurrent monitoring	
• Measuring range:	AC 0,5 ... 5 A
• Auxiliary voltage U_H :	AC 230 V
• time delay by I_{ab} :	1 s
• Width:	22,5 mm

Variants

BA 9053/_11:	same as BA 9053/010 but with inverted relay output (see Function diagram) with time delay by I_{an}
BA 9053/_13:*	same as BA 9053/012 but with inverted relay output (see Function diagram) with time delay by I_{ab}
BA 9053/61:	with UL approval, only with 1 current range up to 10 A, U_H max. AC 120 V
BA 9053/0__:	standard version without options BA 9053/1__ up to BA 9053/6__
BA 9053/1__:	with start-up delay (1 ... 100 s)
BA 9053/2__:	with safe separation according to VDE 0106, not possible for auxiliary supply AC/DC. Measuring ranges up to max. 1 ... 10 A with 5 μ m gold plated contacts
BA 9053/3__:	with 3 measuring ranges,
BA 9053/4__:	1 changeover contact
BA9053/431:	with safe separation, 3 current ranges up to 10 A, 1 changeover contact, AC/DC supply not possible!
BA 9053/5__:	with positive guided contacts
BA 9053/6__:	with manual reset, resetting by disconnecting the power supply
MK 9053/61:	with UL-approval (Canada/USA)
MK 9053/_11:	deenergised on overcurrent
MK 9053/_13:*	energised on undercurrent
MK 9053/0__:	standard version without remote potentiometer
MK 9053/1__:	connection of remote potentiometer for 470 k Ω

* The units BA/MK 9053/_13 are normally used for undercurrent. The delay starts when the current drops under the hysteresis value.

Ordering example for Variants

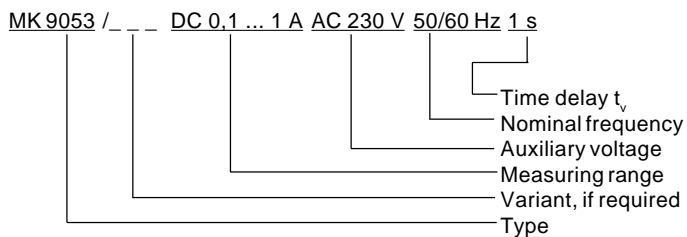
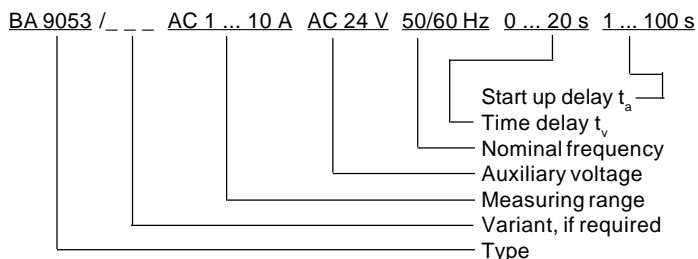

Accessories

for MK 9053	
ET 4752-143:	Marking plate
AD 3:	Remote potentiometer 470 K Ω (article number 0050174)

Setting

Example:
Current relay BA 9053 / MK 9053 AC 0,1 ... 1 A

AC according to type plate:
i.e. the unit is calibrated for AC
0,1 ... 1 A = measuring range

Settings:
upper potentiometer: 0,6 (0,6 x 5 = 3 A)
lower potentiometer: 0,5 (0,5 x 3 = 1,5 A)

The AC - devices can also monitor DC current. The scale offset in this case is: $\Gamma = 0,90 \times I_{eff}$

AC 0,5 ... 5 A is equivalent to DC 0,45 ... 4,5 A

Response value DC 3 A
Hysteresis DC 1,5 A

Settings:
upper potentiometer: 0,66 (0,66 x 4,5 = 3 A)
lower potentiometer: 0,5 (0,5 x 3 = 1,5 A)

Characteristics

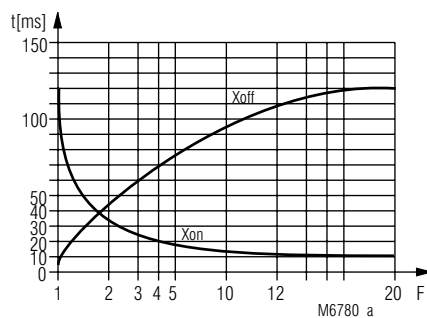

Switching delay

The characteristic shows the switching delay depending on the values of X_{on} - X_{off} when switching the current on or off. A slow current change reduces the delay.

$$F = \frac{I_{applied}}{I_{setting}}$$