

## CURRENT



DAT 25 current transducers convert AC input into load independent DC current & voltage output signal. This signal is highly accurate & proportionally linear to the AC input. T25-I versions convert the AC sinusoidal waveforms to linear DC output calibrated to the RMS value.

### Models

- T25-IS** - single self-powered phase current
- T25-IL** - single phase life-zero current
- T25-I3** - three phase current
- T25-IR** - single phase RMS current

### General Specifications

#### Test voltage

4kV AC rms 1min between terminal/case  
2kV AC rms 1min between  
input/output/auxillary according to IEC801-4

#### Impulse test

5kV, 1.2/50µs according to IEC 255-4

#### Noise test

2.5kV, 1MHz according to IEC 255-22-1

#### Radio Screening

RFI degree complies with VDE0875

#### Working condition

-5 °C to 60 °C, 20-99% RH  
non condensing

#### Storage condition

-20 °C to 70 °C, 20-99% RH  
Non-condensing

#### Humidity

JWE operation class according to  
DIN 40040

#### Stability

100 ppm / °C, < ± 0.2% drift per year,  
non cumulative

#### Magnetic effect

<0.05% change 1M centre 100AT,  
synchronized with line frequency

#### Aux power effect

<0.005% per volt change

### Technical Specifications

#### Input

##### Current

1A, 5A & 10A (others on request)

##### Burden

0.3VA / element  
1VA / element (for T25-IS)

##### permissible overload

2 X rated current continuous,  
10 X rated current - 10 secs,  
25 X rated current - 2 secs,  
50 X rated current - 1 sec

#### Frequency

50 or 60 Hz ± 2hz

#### Output

##### Output ranges

0 ... 1 mA into 0-10k  
0 ... 5 mA into 0-2k  
0 ... 10mA into 0-1k  
0 ... 20 mA into 0-500  
4 ... 20 mA into 0-500

0 ... 1V, min 200  
0 ... 5V, min 1k  
0 ... 10V, min 2k  
1 ... 5V, min 1k  
2 ... 10V, min 2k  
(other ranges on request)

##### Accuracy (23 ± 5 °C)

±0.2%(avg.) ±0.4% (RMS)  
according to IEC 688-1

##### Output load

current - 10V drop max.  
voltage - 5mA drive max.

#### Ripple Factor

less than 0.5% p-p

#### Response time

<400ms

#### Output Adjustment

span & zero adjustments where applicable

### Auxillary Power Supply

#### Standard Range

110V or 220V ±20% 50/60Hz,

<3VA (for T25-IL & T25-IR)  
<8VA (for T25-I3)

#### Options

self power and other AC power supplies up to  
440V ac on request. DC powered models  
available at additional costs

### Physical Specifications

#### Dimensions

**T25-IS / T25-IL / T25-IR**  
45W x 78H x 116D mm

**T25-I3**  
100W x 78H x 116D mm

#### Enclosure code

IP 50 (case)  
IP 30 (terminal)  
according to IEC 529/DIN40050

## Wiring Connections

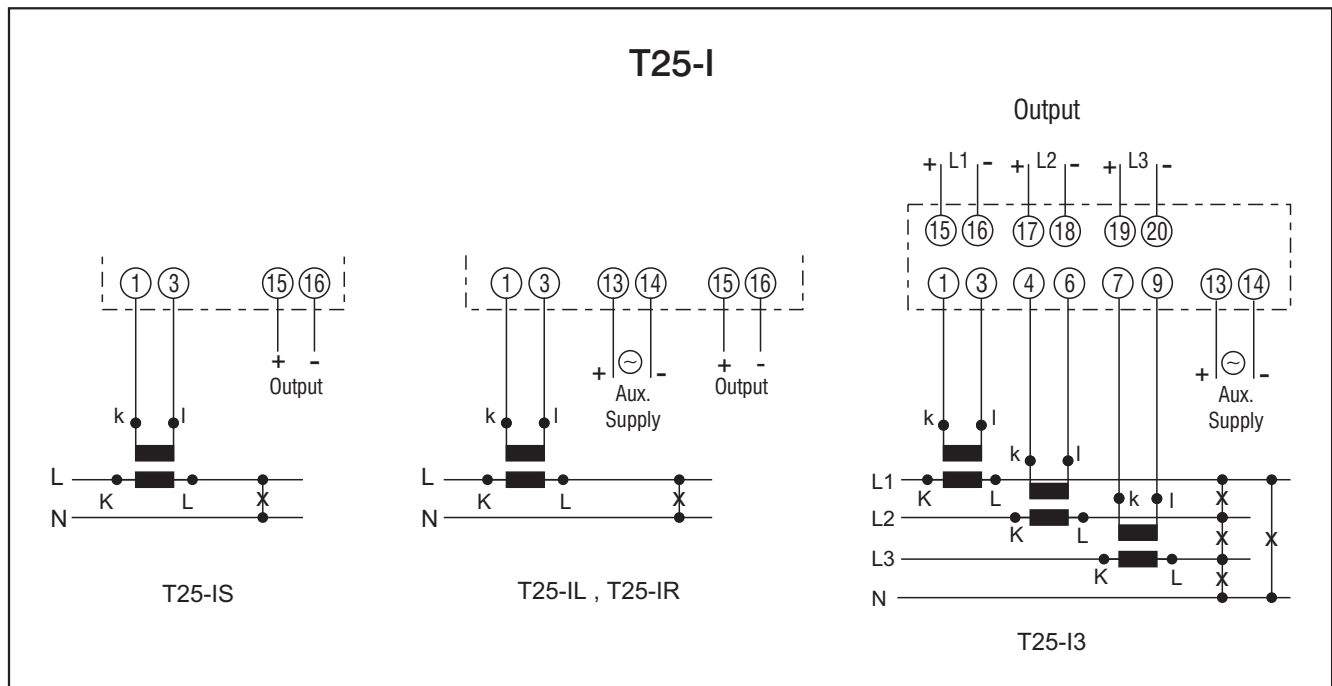

## Dimensional Drawings

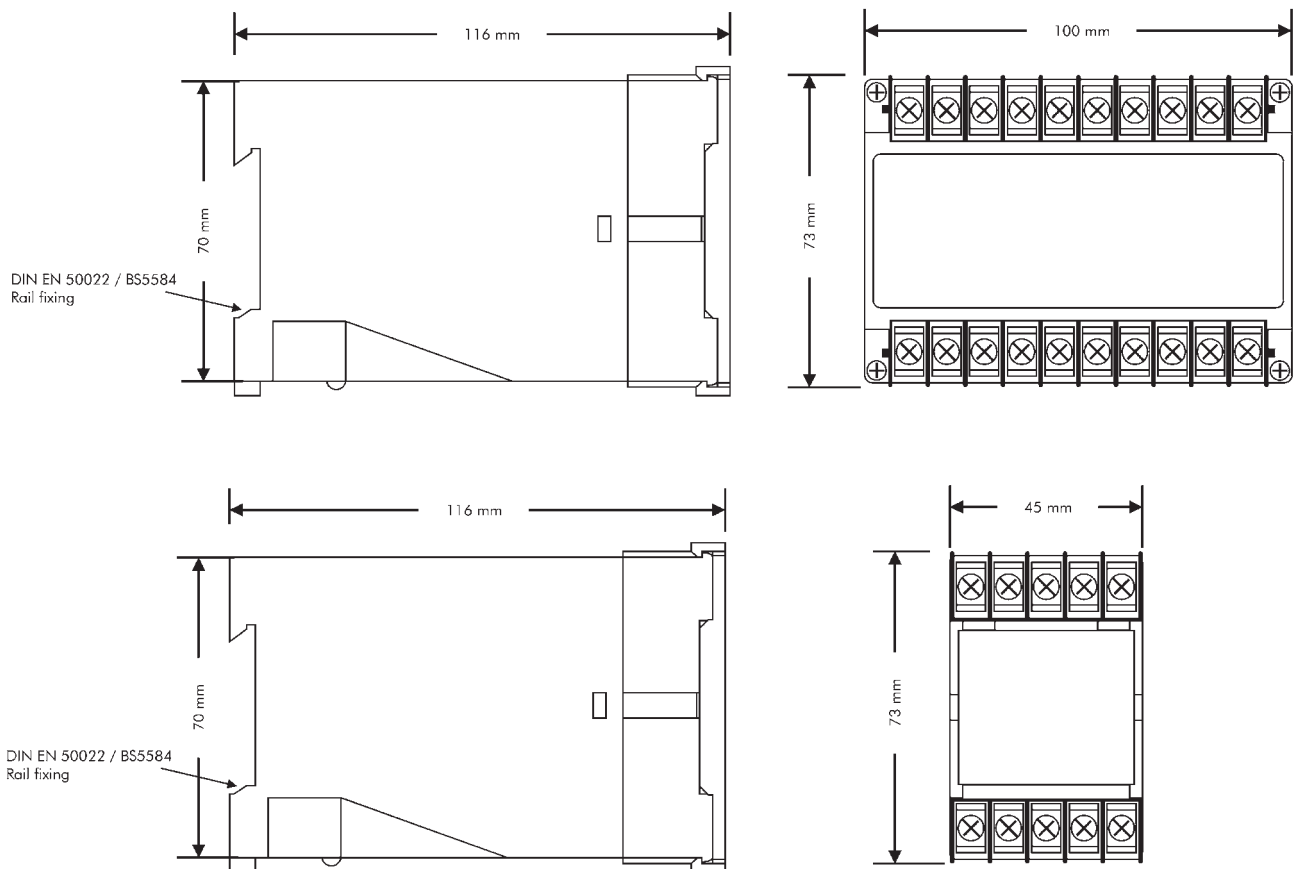

## VOLTAGE



DAT 25 voltage transducers convert AC input into load independent DC current & voltage output signal. This signal is highly accurate & proportionally linear to the AC input. T25-V versions convert the AC sinusoidal waveforms to linear DC output calibrated to the RMS value.

### Models

- T25-VS** - single phase self-powered voltage
- T25-VL** - single phase life-zero voltage
- T25-V3** - three phase voltage
- T25-VR** - single phase RMS voltage

### General Specifications

#### Test voltage

4kV AC rms 1min between terminal/case  
2kV AC rms 1min between  
input/output/auxiliary according to IEC801-4

#### Impulse test

5kV, 1.2/50 $\mu$ s according to IEC 255-4

#### Noise test

2.5kV, 1MHz according to IEC 255-22-1

#### Radio Screening

RFI degree complies with VDE0875

#### Working condition

-5 °C to 60 °C, 20-99% RH  
non condensing

#### Storage condition

-20 °C to 70 °C, 20-99% RH  
Non-condensing

#### Humidity

JWE operation class according to  
DIN 40040

#### Stability

100 ppm / °C, <  $\pm$  0.2% drift per year,  
non cumulative

#### Magnetic effect

<0.05% change 1M centre 100AT,  
synchronized with line frequency

#### Aux power effect

<0.005% per volt change

### Technical Specifications

#### Input

##### Voltage

150V, 300V & 500V

##### Burden

0.3VA / element  
1VA / element (for T25-VS)

##### permissible overload

1.25 X rated voltage continuouts

##### Frequency

50 or 60 Hz  $\pm$  2hz

#### Output

##### Output ranges

0 ... 1 mA into 0-10k  
0 ... 5 mA into 0-2k  
0 ... 10mA into 0-1k  
0 ... 20 mA into 0-500  
4 ... 20 mA into 0-500

0 ... 1V, min 200  
0 ... 5V, min 1k  
0 ... 10V, min 2k  
1 ... 5V, min 1k  
2 ... 10V, min 2k  
(other ranges on request)

##### Accuracy (23 $\pm$ 5 °C)

$\pm$ 0.2%(avg.)  $\pm$ 0.4% (RMS)  
according to IEC 688-1

##### Output load

current - 10V drop max.  
voltage - 5mA drive max.

##### Ripple Factor

less than 0.5% p-p

##### Response time

<400ms

##### Output Adjustment

span & zero adjustments where applicable

### Auxillary Power Supply

#### Standard Range

110V, 220V  $\pm$ 20% 50/60Hz,

<3VA (for T25-VL & T25-VR)  
<8VA (for T25-V3)

#### Options

self power and other AC power supplies up to  
440V ac on request. DC powered models  
available at additional costs

### Physical Specifications

#### Dimensions

**T25-VS / T25-VL / T25-VR**  
45W x 78H x 116D mm

**T25-V3**  
100W x 78H x 116D mm

#### Enclosure code

IP 50 (case)  
IP 30 (terminal)  
according to IEC 529/DIN40050

## Wiring Connections

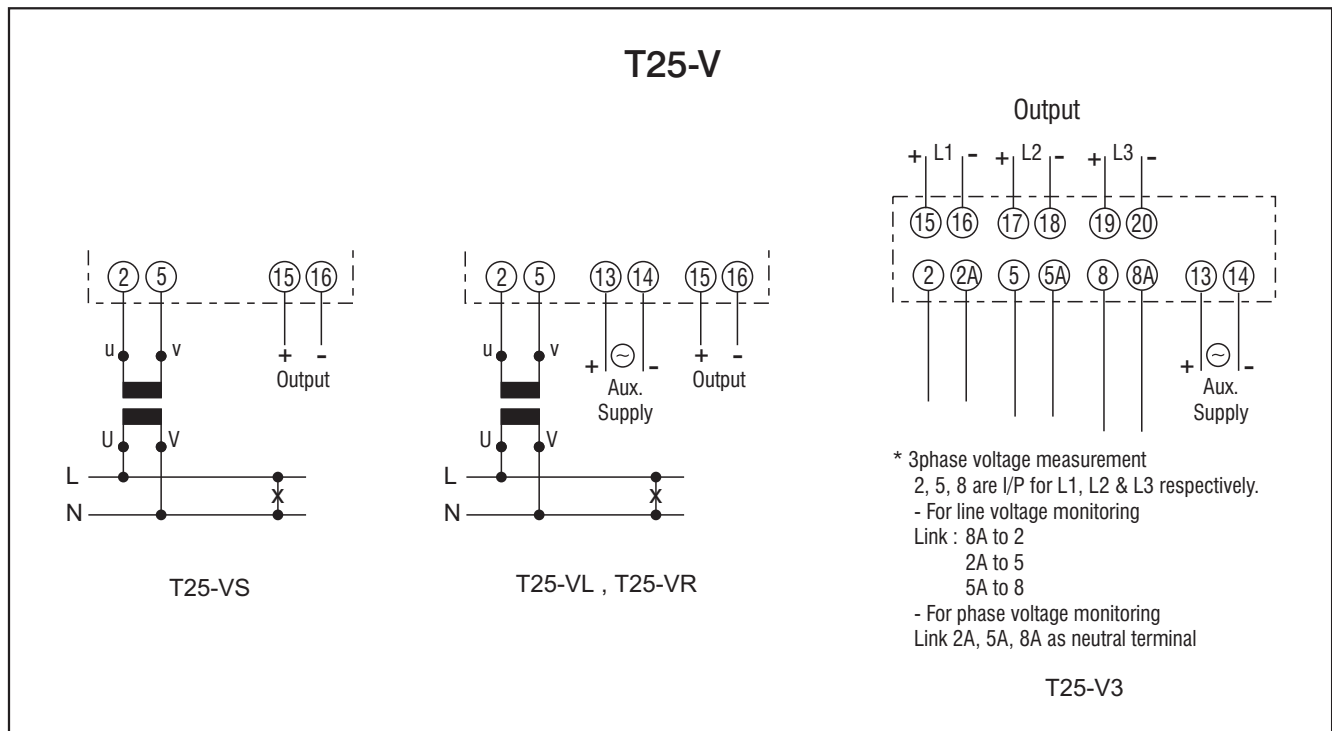

## Dimensional Drawings

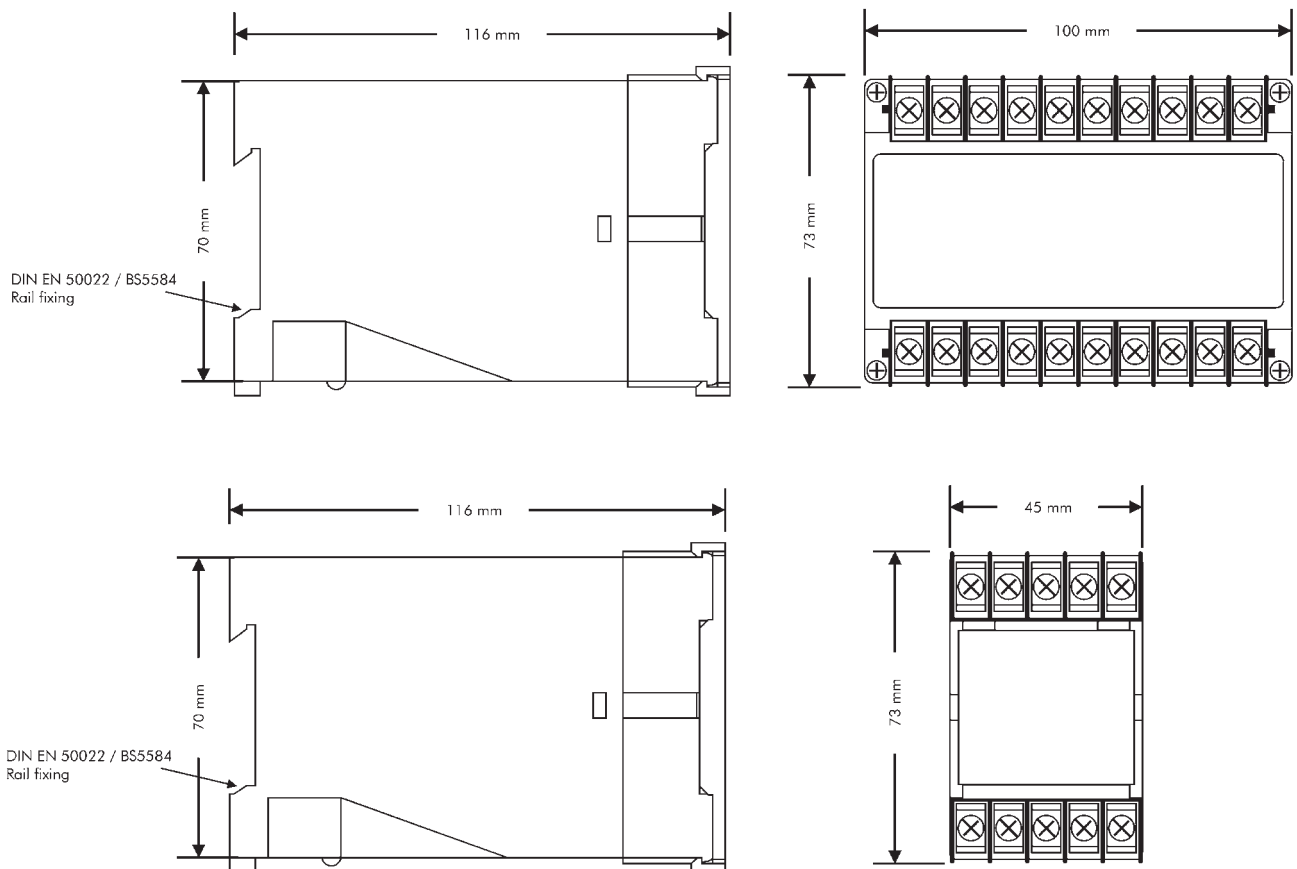

## FREQUENCY



The T25-LF frequency transducer converts AC voltage to a linear DC output signal proportional to the frequency of the input. Employing a crystal based oscillator conversion principle, the measured frequency band is accurately represented by proportional linear DC voltage or current output.

### Model

T25-LF - frequency transducer

### General Specifications

#### Test voltage

4kV AC rms 1min between terminal/case  
2kV AC rms 1min between  
input/output/auxillary according to IEC801-4

#### Impulse test

5kV, 1.2/50 $\mu$ s according to IEC 255-4

#### Noise test

2.5kV, 1MHz according to IEC 255-22-1

#### Radio Screening

RFI degree complies with VDE0875

#### Working condition

-5 °C to 60 °C, 20-99% RH  
non condensing

#### Storage condition

-20 °C to 70 °C, 20-99% RH  
non condensing

#### Humidity

JWE operation class according to  
DIN 40040

#### Stability

100 ppm / °C, <  $\pm$  0.2% drift per year, non  
cumulative

#### Magnetic effect

<0.05% change 1M centre 100AT,  
synchronized with line frequency

#### Aux power effect

<0.005% per volt change

### Technical Specifications

#### Input

##### Voltage

50-300V

##### Burden

0.2VA

##### permissible overload

1.25 X rated voltage continuous

##### Frequency

50 or 60 Hz

##### Measuring range

$\pm$  0.5 Hz,  
 $\pm$  1 Hz,  
 $\pm$  2hz,  
 $\pm$  5Hz &  $\pm$  10Hz

#### Output

##### Output ranges

0 ... 1 mA into 0-10k  
0 ... 5 mA into 0-2k  
0 ... 10mA into 0-1k  
0 ... 20 mA into 0-500  
4 ... 20 mA into 0-500

0 ... 1V, min 200  
0 ... 5V, min 1k  
0 ... 10V, min 2k  
1 ... 5V, min 1k  
2 ... 10V, min 2k  
(other ranges on request)

##### Accuracy (23 $\pm$ 5 °C)

$\pm$  0.025% of rated frequency  
according to IEC 688-1

#### Output load

current - 10V drop max.  
voltage - 5mA drive max.

#### Ripple Factor

less than 0.5% p-p

#### Response time

<400ms

#### Output Adjustment

span & zero adjustments where applicable

#### Auxillary Power Supply

##### Standard Range

110V, 220V  $\pm$  20% 50/60Hz, <3.5VA

##### Options

self power and other AC power supplies up to  
440V ac on request. DC powered models available  
at additional costs

### Physical Specifications

#### Dimensions

100W x 78H x 116D mm

#### Enclosure code

IP 50 (case)  
IP 30 (terminal)  
according to IEC 529/DIN40050

## Wiring Connections

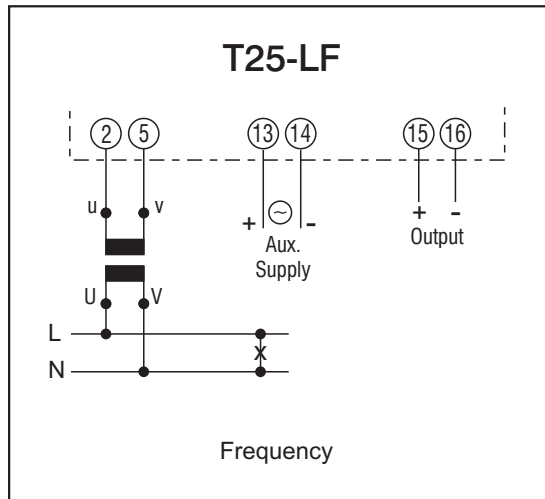

## Dimensional Drawings

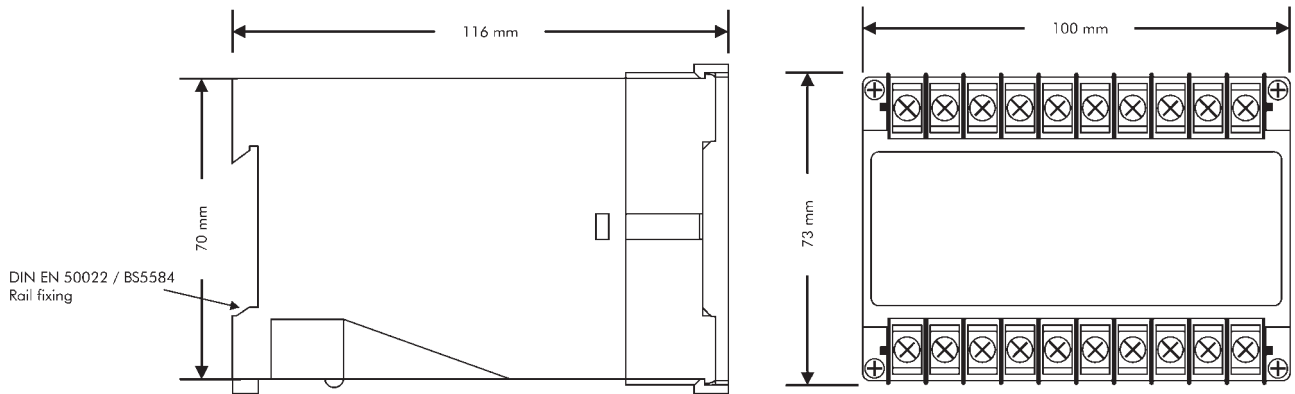

## POWER FACTOR



The zero-crossing detector modulation conversion principle is used to produce a corresponding linear DC output signal proportional to true power factor of the power system. The transducers can be use in a single or three phase system.

### Model

- T25-PF10** - Single phase Power Factor transducer
- T25-PF12** - Three phase Power Factor transducer

### General Specifications

#### Test voltage

4kV AC rms 1min between terminal/case  
2kV AC rms 1min between  
input/output/auxillary according to IEC801-4

#### Impulse test

5kV, 1.2/50 $\mu$ s according to IEC 255-4

#### Noise test

2.5kV, 1MHz according to IEC 255-22-1

#### Radio Screening

RFI degree complies with VDE0875

#### Working condition

-5 °C to 60 °C, 20-99% RH  
non condensing

#### Storage condition

-20 °C to 70 °C, 20-99% RH  
non condensing

#### Humidity

JWE operation class according to  
DIN 40040

#### Stability

100 ppm / °C, <  $\pm$  0.2% drift per year, non  
cumulative

#### Magnetic effect

<0.05% change 1M centre 100AT,  
synchronized with line frequency

#### Aux power effect

<0.005% per volt change

### Technical Specifications

#### Input

##### Voltage

120V, 240V or 415V,  $\pm$  25%

##### Burden

0.2VA

##### permissible overload

1.25 X rated voltage continuous

#### Current

1A, 5A

##### Burden

0.3VA typically

##### permissible overload

2X rated cotinuous,  
10 X rated - 10secs,  
25 X rated - 2 secs,  
50 X rated - 1 sec.

#### Frequency

50 or 60 Hz,  $\pm$  2hz

#### Measuring range

$\pm$  30°,  $\pm$  60°,  $\pm$  90°,  $\pm$  180° & 0-360°

#### Output

##### Output ranges

0 ... 1 mA into 0-10k  
0 ... 5 mA into 0-2k  
0 ... 10mA into 0-1k  
0 ... 20 mA into 0-500  
4 ... 20 mA into 0-500

0 ... 1V, min 200  
0 ... 5V, min 1k  
0 ... 10V, min 2k  
1 ... 5V, min 1k  
2 ... 10V, min 2k  
(other ranges on request)

#### Accuracy (23 $\pm$ 5 °C)

$\pm$  0.2% RO according to IEC 688-1

#### Output load

current - 10V drop max.  
voltage - 5mA drive max.

#### Ripple Factor

less than 0.5% p-p

#### Response time

<400ms

#### Output Adjustment

span & zero adjustments where applicable

#### Auxillary Power Supply

##### Standard Range

110V, 220V  $\pm$  20%  
50/60Hz, <3.5VA

##### Options

self power and other AC power supplies up to  
440V ac on request. DC powered models available  
at additional costs

### Physical Specifications

#### Dimensions

100W x 78H x 116D mm

#### Enclosure code

IP 50 (case)  
IP 30 (terminal)  
according to IEC 529/DIN40050

## Wiring Connections

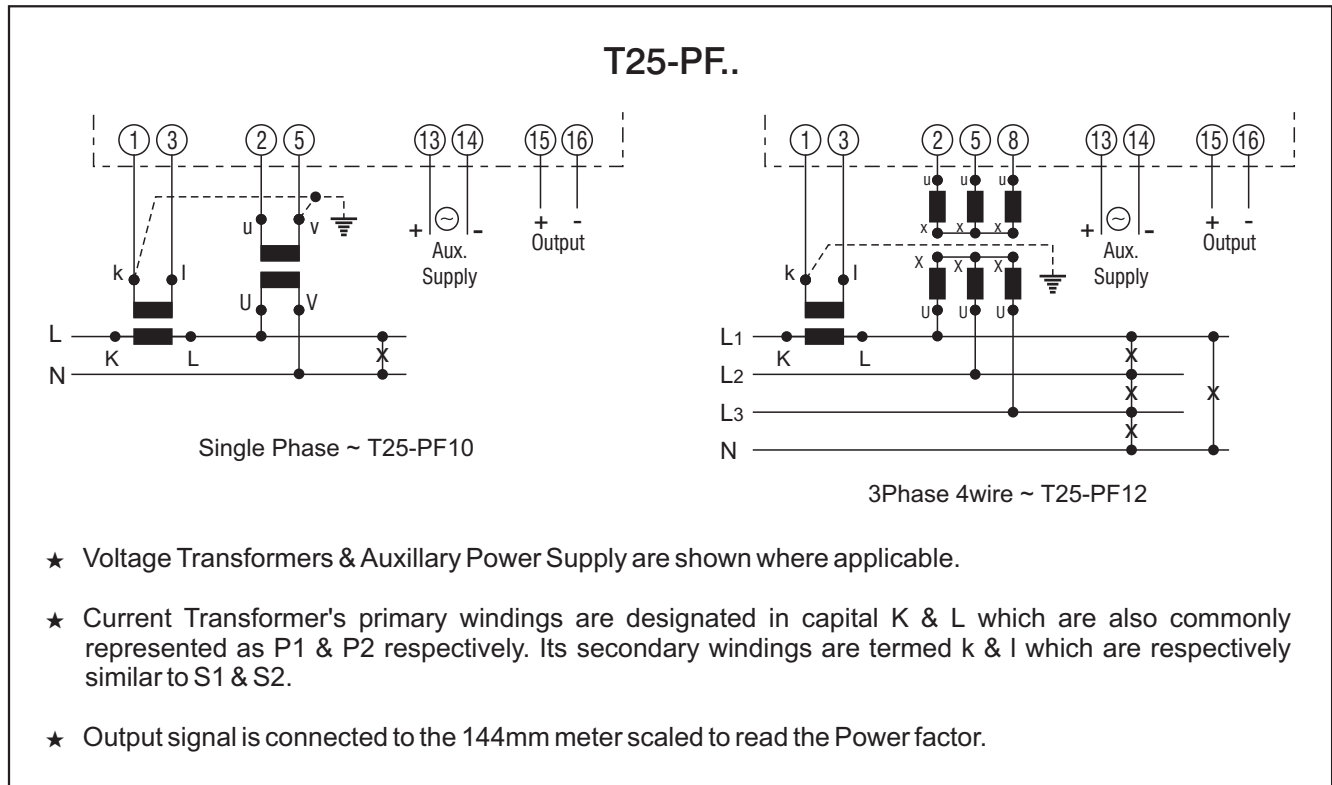

## Dimensional Drawings

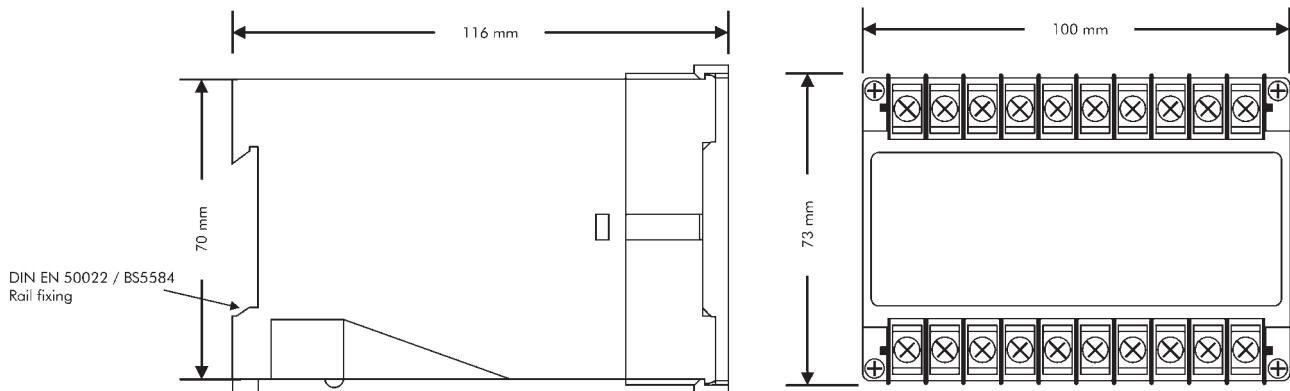

## PHASE ANGLE



The zero-crossing detector modulation conversion principle is used to produce a corresponding linear DC output signal proportional to phase angle of the power system. The transducers can be use in a single or three phase system.

### Model

- T25-PA10** - Single phase Phase Angle transducer
- T25-PA12** - Three phase Phase Angle transducer

### General Specifications

#### Test voltage

4kV AC rms 1min between terminal/case  
2kV AC rms 1min between  
input/output/auxillary according to IEC801-4

#### Impulse test

5kV, 1.2/50 $\mu$ s according to IEC 255-4

#### Noise test

2.5kV, 1MHz according to IEC 255-22-1

#### Radio Screening

RFI degree complies with VDE0875

#### Working condition

-5 °C to 60 °C, 20-99% RH  
non condensing

#### Storage condition

-20 °C to 70 °C, 20-99% RH  
non condensing

#### Humidity

JWE operation class according to  
DIN 40040

#### Stability

100 ppm/°C, <  $\pm$  0.2% drift per year,  
non cumulative

#### Magnetic effect

<0.05% change 1M centre 100AT,  
synchronized with line frequency

#### Aux power effect

<0.005% per volt change

### Technical Specifications

#### Input

##### Voltage

120V, 240V or 415V,  $\pm$  25%

##### Burden

0.2VA

##### permissible overload

1.25 X rated voltage continuous

#### Current

1A, 5A

##### Burden

0.3VA typically

##### Permissible overload

2 X rated cotinuous,  
10 X rated - 10secs,  
25 X rated - 2 secs,  
50 X rated - 1 sec.

#### Frequency

50 or 60 Hz,  $\pm$  2hz

#### Measuring range

$\pm$  30°,  $\pm$  60°,  $\pm$  90°,  $\pm$  80° & 0-360°

#### Output

##### Output ranges

0 ... 1 mA into 0-10k  
0 ... 5 mA into 0-2k  
0 ... 10mA into 0-1k  
0 ... 20 mA into 0-500  
4 ... 20 mA into 0-500

0 ... 1V, min 200

0 ... 5V, min 1k

0 ... 10V, min 2k

1 ... 5V, min 1k

2 ... 10V, min 2k

(other ranges on request)

#### Accuracy (23 $\pm$ 5 °C)

$\pm$  0.2% RO according to IEC 688-1

#### Output load

current - 10V drop max.  
voltage - 5mA drive max.

#### Ripple Factor

less than 0.5% p-p

#### Response time

<400ms

#### Output Adjustment

span & zero adjustments where applicable

### Auxillary Power Supply

#### Standard Range

110V, 220V  $\pm$  20%  
50/60Hz, <3.5VA

#### Options

self power and other AC power supplies up to  
440V ac on request. DC powered models available  
at additional costs

### Physical Specifications

#### Dimensions

100W x 78H x 116D mm

#### Enclosure code

IP 50 (case)

IP 30 (terminal)

according to IEC 529/DIN40050

## Wiring Connections

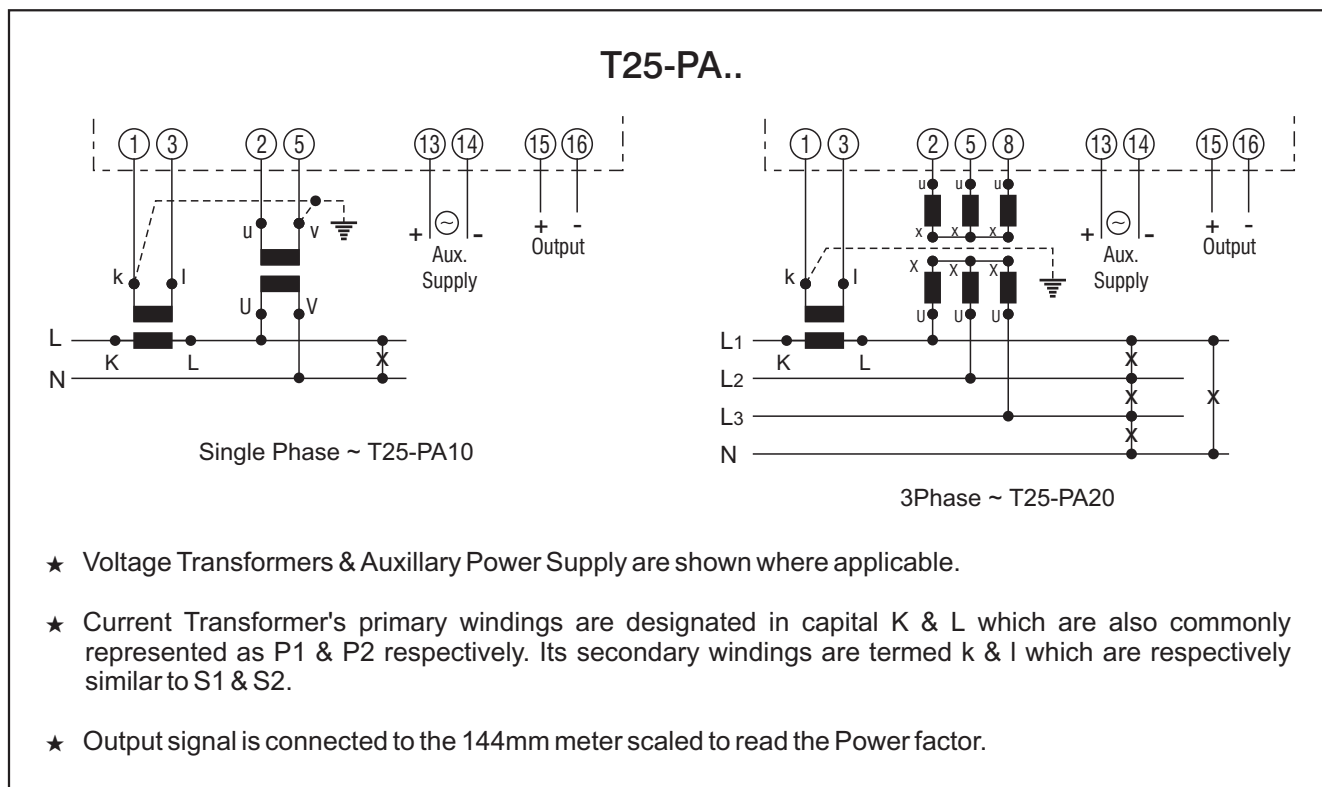

## Dimensional Drawings

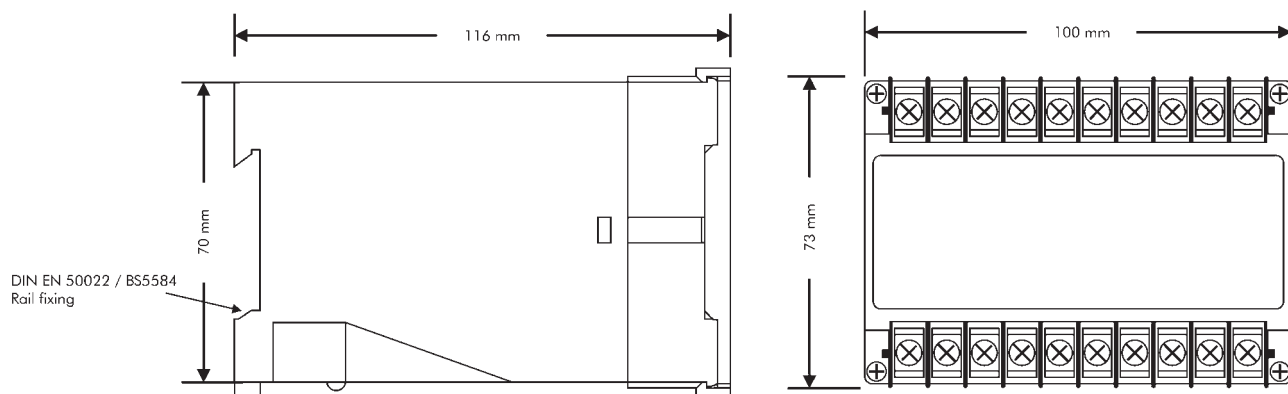

## ACTIVE POWER



Time-division-multiplication (TDM) principle of computing the AC power inputs to a corresponding DC output value. The measurements of active power of single or three phase balanced or unbalanced systems, are precisely converted to a highly accurate linear DC voltage or current output.

### Model

- T25-W10** - single phase watt transducer
- T25-W12** - 3ph 3w balanced load watt transducer
- T25-W13** - 3ph 4 w balanced load watt transducer
- T25-W20** - 3ph 3w unbalanced load watt transducer
- T25-W30** - 3ph 4w unbalanced load watt transducer

### General Specifications

#### Test voltage

4kV AC rms 1min between terminal/case  
2kV AC rms 1min between  
input/output/auxillary according to IEC801-4

#### Impulse test

5kV, 1.2/50 $\mu$ s according to IEC 255-4

#### Noise test

2.5kV, 1MHz according to IEC 255-22-1

#### Radio Screening

RFI degree complies with VDE0875

#### Working condition

-5 °C to 60 °C, 20-99% RH  
non condensing

#### Storage condition

-20 °C to 70 °C, 20-99% RH  
non condensing

#### Humidity

JWE operation class according to  
DIN 40040

#### Stability

100 ppm / °C, <  $\pm$  0.2% drift per year,  
non cumulative

#### Magnetic effect

<0.05% change 1M centre 100AT,  
synchronized with line frequency

#### Aux power effect

<0.005% per volt change

### Technical Specifications

#### Input

##### Voltage

69V (3ph 4w), 120V, 240V or  
415V,  $\pm$  25%

##### Burden

0.2VA

##### permissible overload

1.25 X rated voltage continuous

##### Current

1A, 5A

##### Burden

0.3VA typically

##### permissible overload

2 X rated cotinuous,  
10 X rated - 10secs,  
25 X rated - 2 secs,  
50 X rated - 1 sec.

##### Frequency

50 or 60 Hz,  $\pm$  2hz

#### Output

##### Output ranges

0 ... 1 mA into 0-10k  
0 ... 5 mA into 0-2k  
0 ... 10mA into 0-1k  
0 ... 20 mA into 0-500  
4 ... 20 mA into 0-500

0 ... 1V, min 200

0 ... 5V, min 1k

0 ... 10V, min 2k

1 ... 5V, min 1k

2 ... 10V, min 2k

(other ranges on request)

#### Accuracy (23 $\pm$ 5 °C)

$\pm$  0.2 % RO according to IEC 688-1

#### Output load

current - 10V drop max.  
voltage - 5mA drive max.

#### Ripple Factor

less than 0.5% p-p

#### Response time

<400ms

#### Output Adjustment

span & zero adjustments where applicable

### Auxiliary Power Supply

#### Standard Range

110V, 220V  $\pm$  20% 50/60Hz, <7VA

#### Options

self power and other AC power supplies up to  
440V ac on request. DC powered models  
available at additional costs

### Physical Specifications

#### Dimensions

100W x 78H x 116D mm

#### Enclosure code

IP 50 (case)

IP 30 (terminal)

according to IEC 529/DIN40050

# Wiring Connections

## T25-W..

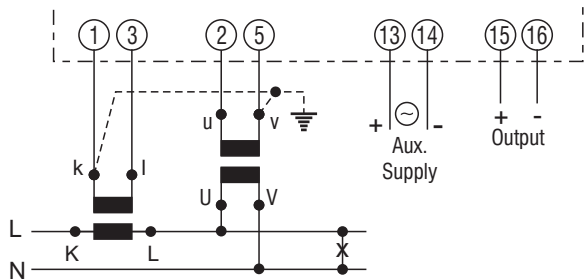

Single Phase ~ T25-W10

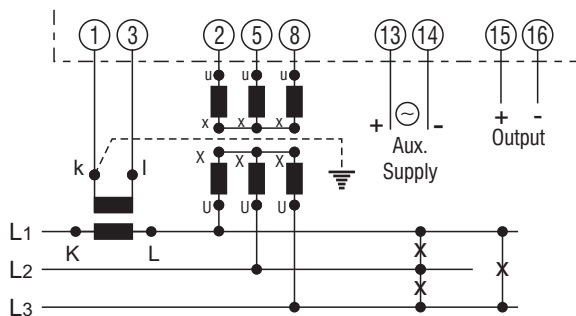

3Phase 3Wire Balanced Load  
T25-W12

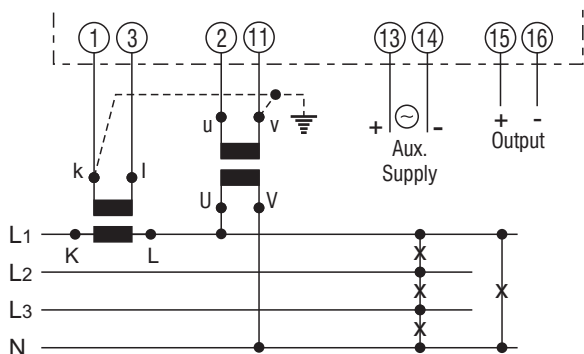

3Phase 4Wire Balanced Load  
T25-W13

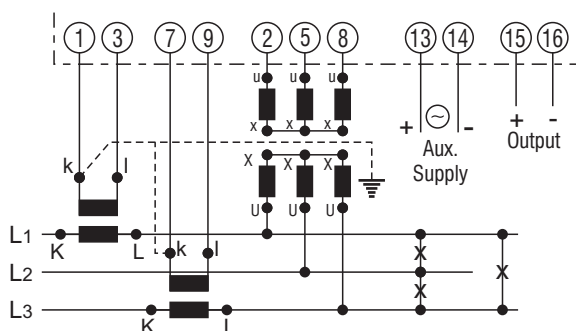

3Phase 3Wire Unbalanced Load  
T25-W20

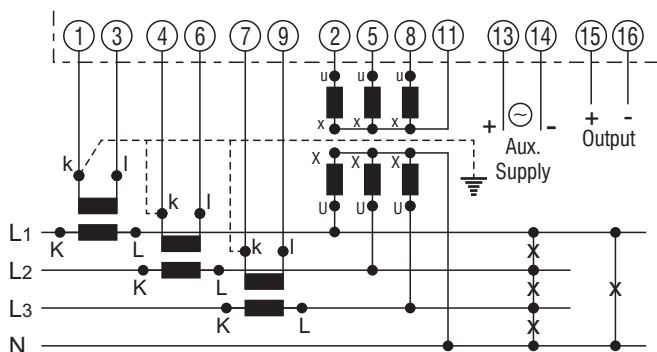

3Phase 4Wire Unbalanced Load  
T25-W30

★ Voltage Transformers & Auxillary Power Supply are shown where applicable.

★ Current Transformer's primary windings are designated in capital K & L which are also commonly represented as P1 & P2 respectively. Its secondary windings are termed k & l which are respectively similar to S1 & S2.

# Dimensional Drawings

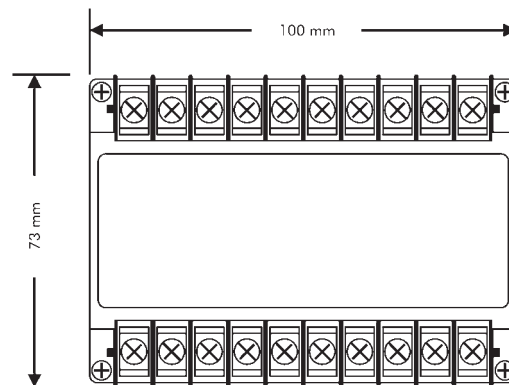
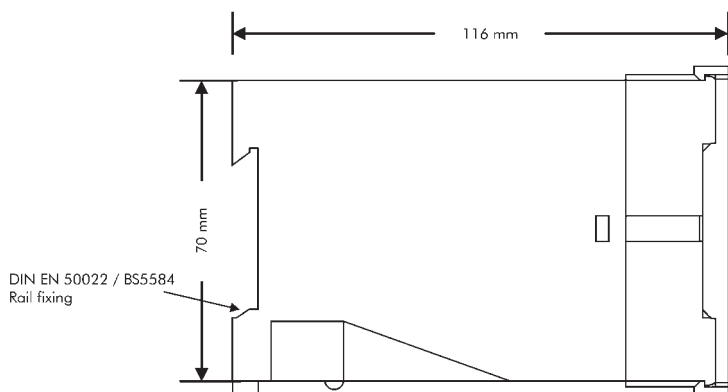

## REACTIVE POWER



Time-division-multiplication (TDM) principle of computing the AC power inputs to a corresponding DC output value. The measurements of reactive power of three phase balanced or unbalanced systems, are precisely converted to a highly accurate linear DC voltage or current output.

### Model

<b>T25-B12</b>	-	3ph 3w balanced load var transducer
<b>T25-B13</b>	-	3ph 4w balanced load var transducer
<b>T25-B20</b>	-	3ph 3w unbalanced load var transducer
<b>T25-B30</b>	-	3ph 4w unbalanced load var transducer

## General Specifications

### Test voltage

4kV AC rms 1min between terminal/case  
2kV AC rms 1min between  
input/output/auxiliary according to IEC801-4

### Impulse test

5kV, 1.2/50 $\mu$ s according to IEC 255-4

### Noise test

2.5kV, 1MHz according to IEC 255-22-1

### Radio Screening

RFI degree complies with VDE0875

### Working condition

-5 °C to 60 °C, 20-99% RH  
non condensing

### Storage condition

-20 °C to 70 °C, 20-99% RH  
non condensing

### Humidity

JWE operation class according to  
DIN 40040

### Stability

100 ppm / °C, <  $\pm$  0.2% drift per year, non  
cumulative

### Magnetic effect

<0.05% change 1M centre 100AT,  
synchronized with line frequency

### Aux power effect

<0.005% per volt change

## Technical Specifications

### Input

#### Voltage

69V (3ph 4w), 120V, 240V or  
415V,  $\pm$  25%

#### Burden

0.2VA

#### permissible overload

1.25 X rated voltage continuous

#### Current

1A, 5A

#### Burden

0.3VA typically

#### permissible overload

2 X rated continuous,  
10 X rated - 10secs,  
25 X rated - 2 secs,  
50 X rated - 1 sec.

#### Frequency

50 or 60 Hz,  $\pm$  2hz

### Output

#### Output ranges

0 ... 1 mA into 0-10k  
0 ... 5 mA into 0-2k  
0 ... 10mA into 0-1k  
0 ... 20 mA into 0-500  
4 ... 20 mA into 0-500

0 ... 1V, min 200

0 ... 5V, min 1k

0 ... 10V, min 2k

1 ... 5V, min 1k

2 ... 10V, min 2k

(other ranges on request)

### Accuracy (23 $\pm$ 5 °C)

$\pm$  0.2% RO according to IEC 688-1

### Output load

current - 10V drop max.  
voltage - 5mA drive max.

### Ripple Factor

less than 0.5% p-p

### Response time

<400ms

### Output Adjustment

span & zero adjustments where applicable

## Auxiliary Power Supply

### Standard Range

110V, 220V  $\pm$  20% 50/60Hz, <3.5VA

### Options

self power and other AC power supplies up to  
440V ac on request. DC powered models available  
at additional costs

## Physical Specifications

### Dimensions

100W x 78H x 116D mm

### Enclosure code

IP 50 (case)

IP 30 (terminal)

according to IEC 529/DIN40050

## Wiring Connections

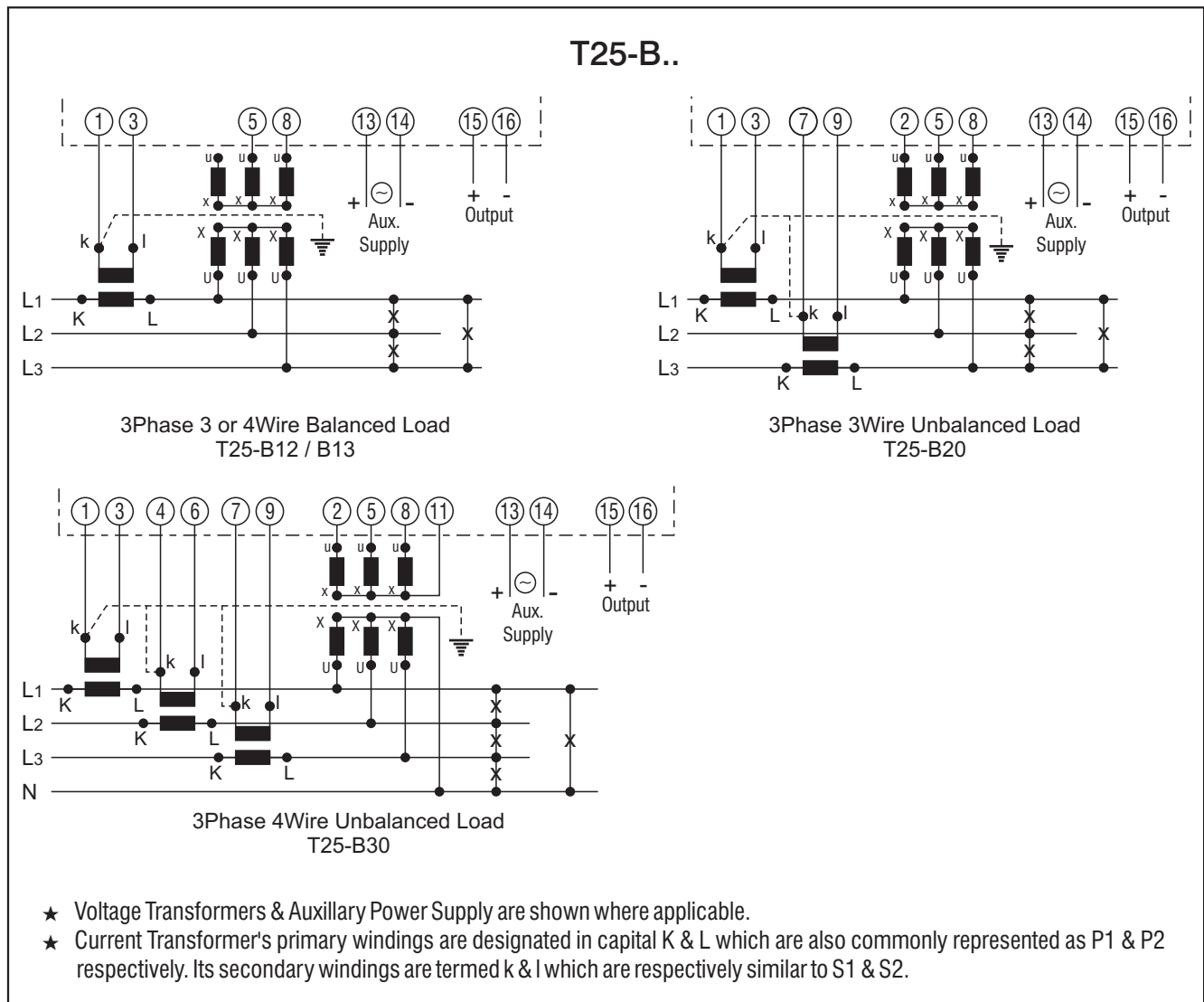

## Dimensional Drawings

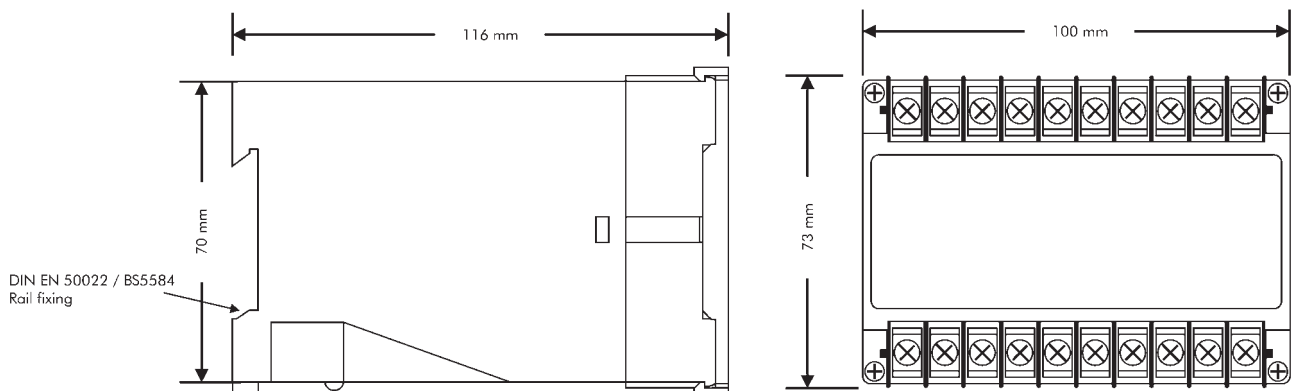

## ACTIVE & REACTIVE POWER



T25-WB is a combined watt and var electronic transducer utilising the time-division-multiplication (TDM) principle of computing the AC active and reactive power inputs to produce two corresponding DC output values from a single unit.

### Model

- T25-WB12** - 3ph 3w balanced load watt & var transducer
- T25-WB13** - 3ph 4 w balanced load watt & var transducer
- T25-WB20** - 3ph 3w unbalanced load watt & var transducer
- T25-WB30** - 3ph 4w unbalanced load watt & var transducer

### General Specifications

#### Test voltage

4kV AC rms 1min between terminal/case  
2kV AC rms 1min between  
input/output/auxillary according to IEC801-4

#### Impulse test

5kV, 1.2/50µs according to IEC 255-4

#### Noise test

2.5kV, 1MHz according to IEC 255-22-1

#### Radio Screening

RFI degree complies with VDE0875

#### Working condition

-5 °C to 60 °C, 20-99% RH  
non condensing

#### Storage condition

-20 °C to 70 °C, 20-99% RH  
non condensing

#### Humidity

JWE operation class according to  
DIN 40040

#### Stability

100 ppm / °C, < ± 0.2% drift per year, non  
cumulative

#### Magnetic effect

<0.05% change 1M centre 100AT,  
synchronized with line frequency

#### Aux power effect

<0.005% per volt change

### Technical Specifications

#### Input

##### Voltage

69V (3ph 4w), 120V, 240V or 415V, ±  
25%

##### Burden

0.2VA

##### permissible overload

1.25 X rated voltage continuous

##### Current

1A, 5A

##### Burden

0.3VA typically

##### permissible overload

2 X rated continuous,  
10 X rated - 10secs,  
25 X rated - 2 secs,  
50 X rated - 1 sec.

##### Frequency

50 or 60 Hz, ± 2hz

#### Output

##### Output ranges

0 ... 1 mA into 0-10k  
0 ... 5 mA into 0-2k  
0 ... 10mA into 0-1k  
0 ... 20 mA into 0-500  
4 ... 20 mA into 0-500

0 ... 1V, min 200

0 ... 5V, min 1k

0 ... 10V, min 2k

1 ... 5V, min 1k

2 ... 10V, min 2k

(other ranges on request)

#### Accuracy (23 ± 5 °C)

± 0.2% RO according to IEC 688-1

#### Output load

current - 10V drop max.  
voltage - 5mA drive max.

#### Ripple Factor

less than 0.5% p-p

#### Response time

<400ms

#### Output Adjustment

span & zero adjustments where applicable

#### Auxillary Power Supply

##### Standard Range

110V, 220V ± 20% 50/60Hz, <7VA

##### Options

self power and other AC power supplies up to  
440V ac on request. DC powered models available  
at additional costs

### Physical Specifications

#### Dimensions

100W x 78H x 116D mm

#### Enclosure code

IP 50 (case)

IP 30 (terminal)

according to IEC 529/DIN40050

# Wiring Connections

## T25-WB

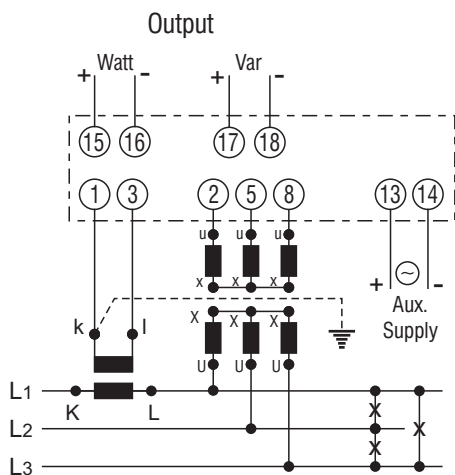

3Phase 3Wire Balanced Load  
T25-WB12

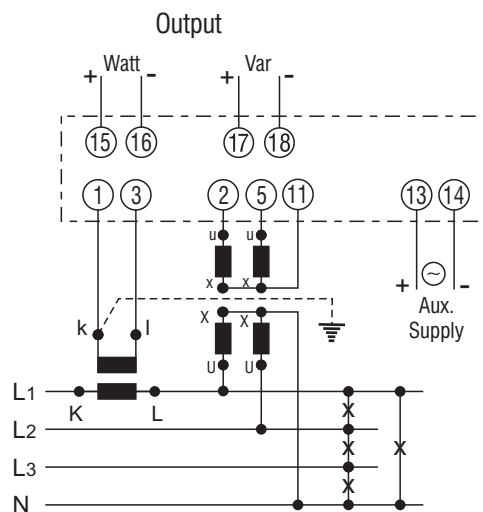

3Phase 4Wire Balanced Load  
T25-WB13

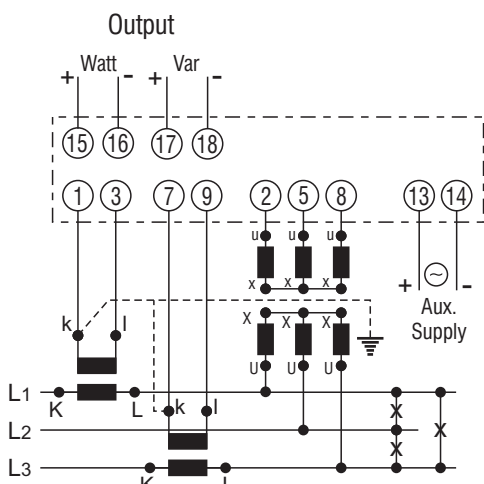

3Phase 3Wire Unbalanced Load  
T25-WB20

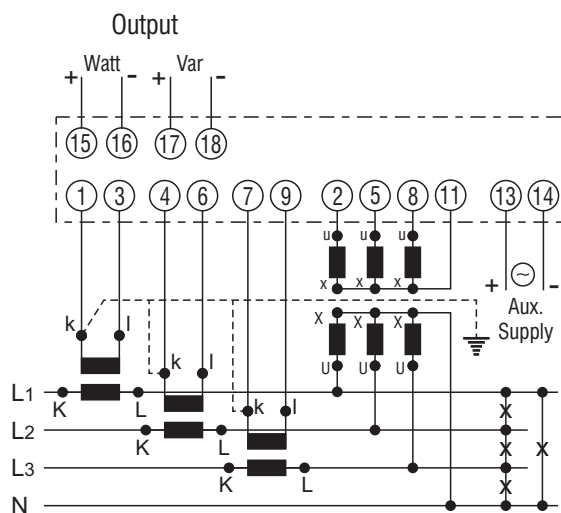

3Phase 4Wire Unbalanced Load  
T25-WB30

- ★ Voltage Transformers & Auxillary Power Supply are shown where applicable.
- ★ Current Transformer's primary windings are designated in capital K & L which are also commonly represented as P1 & P2 respectively. Its secondary windings are termed k & l which are respectively similar to S1 & S2.

## Dimensional Drawings

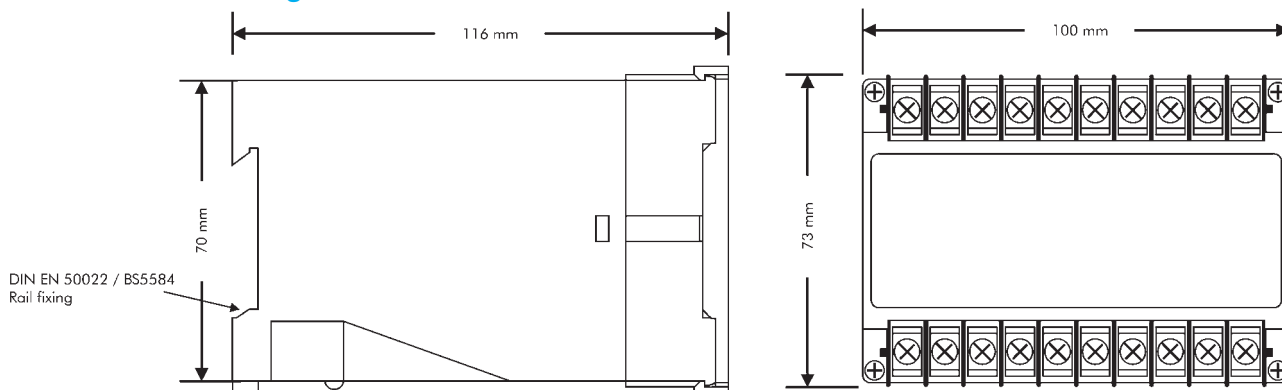

## ACTIVE POWER & ENERGY



The T25-WE are electronic transducers converting active power and energy in single or three phase balanced or unbalanced systems to simultaneously produce an analogue DC output for instantaneous power signal and a digital pulse output for cumulative energy signal.

### Model

- T25-WE10** - single phase watt & watt-hour transducer
- T25-WE12** - 3ph 3w bal. load watt & watt-hour transducer
- T25-WE13** - 3ph 4w bal. load watt & watt-hour transducer
- T25-WE20** - 3ph 3w unbalanced load watt & watt-hour transducer
- T25-WE30** - 3ph 4w unbalanced load watt & watt-hour transducer

### General Specifications

#### Test voltage

4kV AC rms 1min between terminal/case  
2kV AC rms 1min between  
input/output/auxiliary according to IEC801-4

#### Impulse test

5kV, 1.2/50µs according to IEC 255-4

#### Noise test

2.5kV, 1MHz according to IEC 255-22-1

#### Radio Screening

RFI degree complies with VDE0875

#### Working condition

-5 °C to 60 °C, 20-99% RH  
non condensing

#### Storage condition

-20 °C to 70 °C, 20-99% RH  
non condensing

#### Humidity

JWE operation class according to  
DIN 40040

#### Stability

100 ppm / °C, < ± 0.2% drift per year, non  
cumulative

#### Magnetic effect

<0.05% change 1M centre 100AT,  
synchronized with line frequency

#### Aux power effect

<0.005% per volt change

### Technical Specifications

#### Input

##### Voltage

69V (3ph 4w), 120V, 240V or  
415V, ± 25%

##### Burden

0.2VA

##### permissible overload

1.25 X rated voltage continuous

##### Current

1A, 5A

##### Burden

0.3VA typically

##### permissible overload

2 X rated continuous,  
10 X rated - 10secs,  
25 X rated - 2 secs,  
50 X rated - 1 sec.

##### Frequency

50 or 60 Hz, ± 2hz

#### Output

##### Output ranges (analogue)

0 ... 1 mA into 0-10k  
0 ... 5 mA into 0-2k  
0 ... 10mA into 0-1k  
0 ... 20 mA into 0-500  
4 ... 20 mA into 0-500

0 ... 1V, min 200

0 ... 5V, min 1k

0 ... 10V, min 2k

1 ... 5V, min 1k

2 ... 10V, min 2k

(other ranges on request)

#### Accuracy (23 ± 5 °C)

± 0.2% RO according to IEC 688-1

#### Output load

current - 10V drop max.  
voltage - 5mA drive max.

#### Output rating (digital)

Open collector type - max.30V/30mA;  
reed relay type - max. 50V/40mA  
export pulse optional

#### Ripple Factor

less than 0.5% p-p

#### Response time

<400ms

#### Output Adjustment

span & zero adjustments where applicable

### Auxiliary Power Supply

#### Standard Range

110V, 220V ± 20% 50/60Hz, <4VA

#### Options

self power and other AC power supplies up to  
440V ac on request. DC powered models available  
at additional costs

### Physical Specifications

#### Dimensions

100W x 78H x 116D mm

#### Enclosure code

IP 50 (case)

IP 30 (terminal)

according to IEC 529/DIN40050

# Wiring Connections

## T25-WE

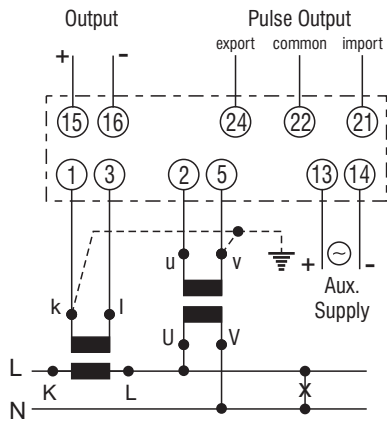

Single Phase ~ T25-WE10

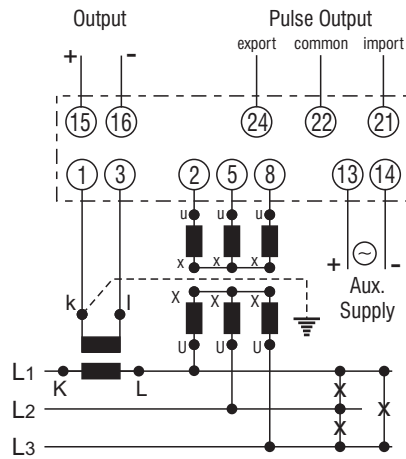

3Phase 3Wire Balanced Load  
T25-WE12

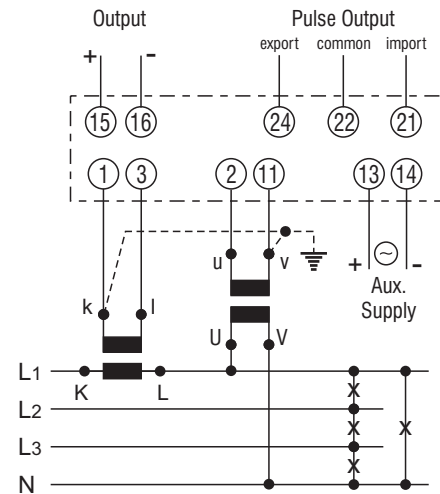

3Phase 4Wire Balanced Load  
T25-WE13

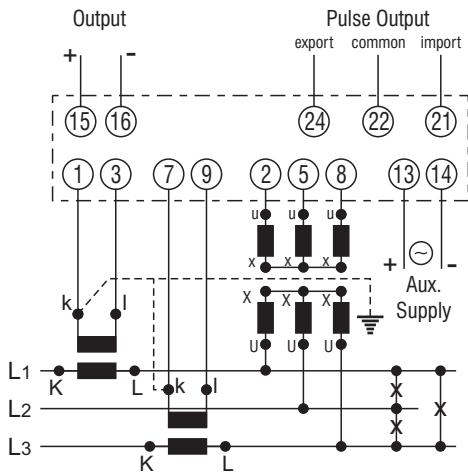

3Phase 3Wire Unbalanced Load  
T25-WE20

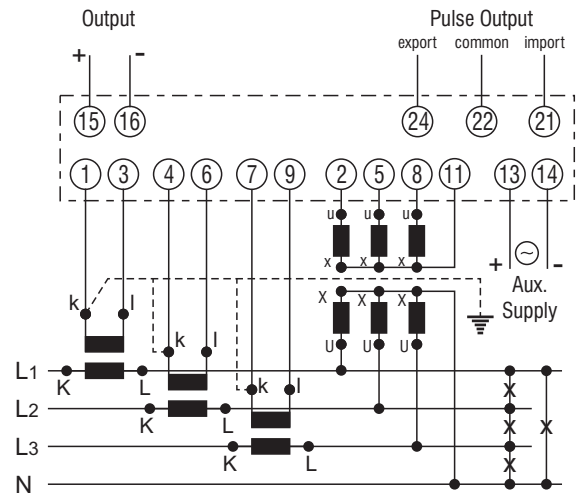

3Phase 4Wire Unbalanced Load  
T25-WE30

# Dimensional Drawings

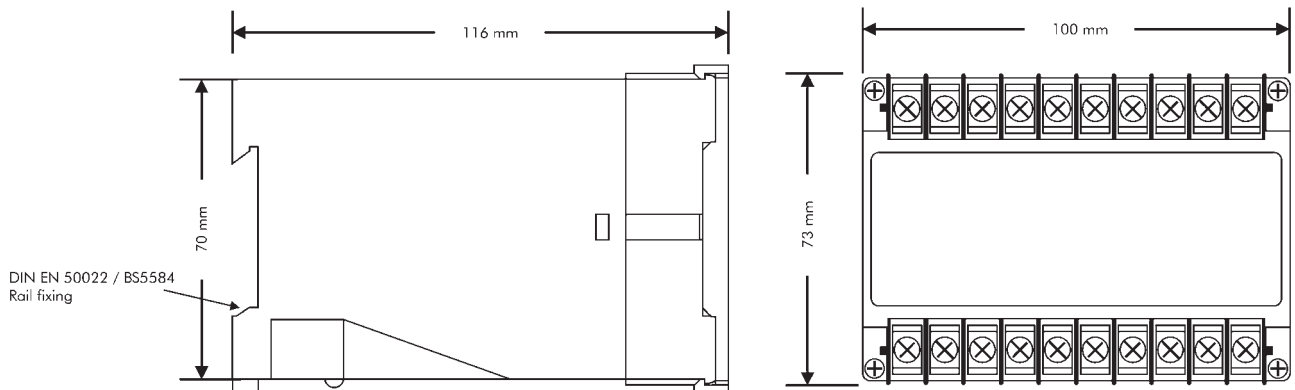

## REACTIVE POWER & ENERGY



The T25-BE are electronic transducers converting reactive power and energy in three phase balanced or unbalanced systems to simultaneously produce an analogue DC output for instantaneous power signal and a digital pulse output for cumulative energy signal.

### Model

<b>T25-BE12</b>	-	3ph 3w bal. load var & var-hour transducer
<b>T25-BE13</b>	-	3ph 4w bal. load var & var-hour transducer
<b>T25-BE20</b>	-	3ph 3w unbalanced load var & var-hour transducer
<b>T25-BE30</b>	-	3ph 4w unbalanced load var & var-hour transducer

### General Specifications

#### Test voltage

4kV AC rms 1min between terminal/case  
2kV AC rms 1min between  
input/output/auxillary according to IEC801-4

#### Impulse test

5kV, 1.2/50 $\mu$ s according to IEC 255-4

#### Noise test

2.5kV, 1MHz according to IEC 255-22-1

#### Radio Screening

RFI degree complies with VDE0875

#### Working condition

-5 °C to 60 °C, 20-99% RH  
non condensing

#### Storage condition

-20 °C to 70 °C, 20-99% RH  
non condensing

#### Humidity

JWE operation class according to  
DIN 40040

#### Stability

100 ppm / °C, <  $\pm$  0.2% drift per year, non  
cumulative

#### Magnetic effect

<0.05% change 1M centre 100AT,  
synchronized with line frequency

#### Aux power effect

<0.005% per volt change

### Technical Specifications

#### Input

##### Voltage

69V (3ph 4w), 120V, 240V or  
415V  $\pm$  25%

##### Burden

0.2VA

##### permissible overload

1.25 X rated voltage continuous

##### Current

1A, 5A

##### Burden

0.3VA typically

##### permissible overload

2 X rated cotinuous,  
10 X rated - 10secs,  
25 X rated - 2 secs,  
50 X rated - 1 sec.

##### Frequency

50 or 60 Hz,  $\pm$  2hz

#### Output

##### Output ranges (analogue)

0 ... 1 mA into 0-10k  
0 ... 5 mA into 0-2k  
0 ... 10mA into 0-1k  
0 ... 20 mA into 0-500  
4 ... 20 mA into 0-500

0 ... 1V, min 200

0 ... 5V, min 1k

0 ... 10V, min 2k

1 ... 5V, min 1k

2 ... 10V, min 2k

(other ranges on request)

#### Accuracy (23 $\pm$ 5 °C)

$\pm$  0.2% RO according to IEC 688-1

#### Output load

current - 10V drop max.  
voltage - 5mA drive max.

#### Output rating (digital)

Open collector type - max.30V/30mA;  
reed relay type - max. 50V/40mA  
export pulse optional

#### Ripple Factor

less than 0.5% p-p

#### Response time

<400ms

#### Output Adjustment

span & zero adjustments where applicable

### Auxillary Power Supply

#### Standard Range

110V, 220V  $\pm$  20% 50/60Hz, < 4VA

#### Options

self power and other AC power supplies up to  
440V ac on request. DC powered models available  
at additional costs

### Physical Specifications

#### Dimensions

100W x 78H x 116D mm

#### Enclosure code

IP 50 (case)

IP 30 (terminal)

according to IEC 529/DIN40050

## Wiring Connections

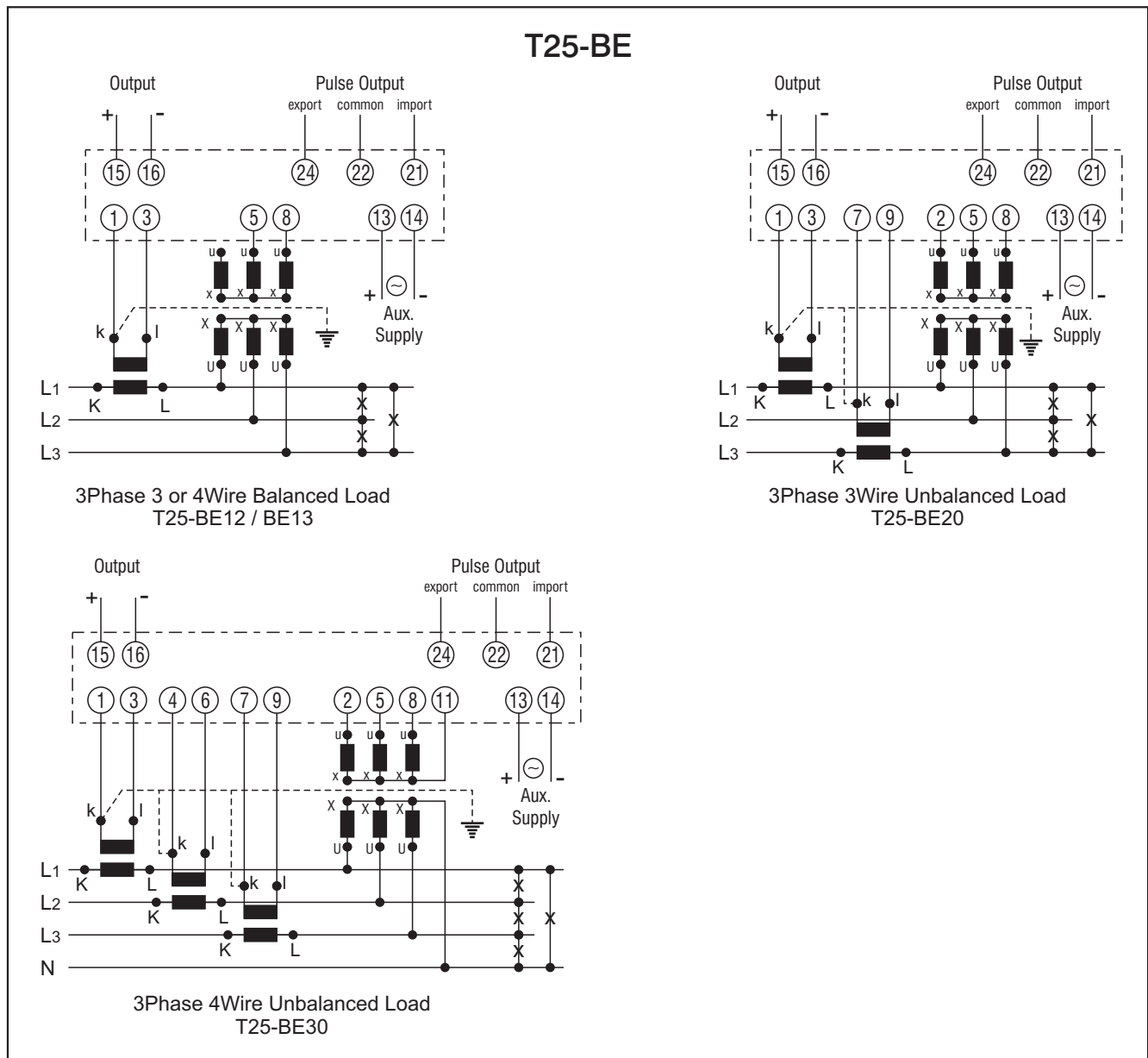

## Dimensional Drawings

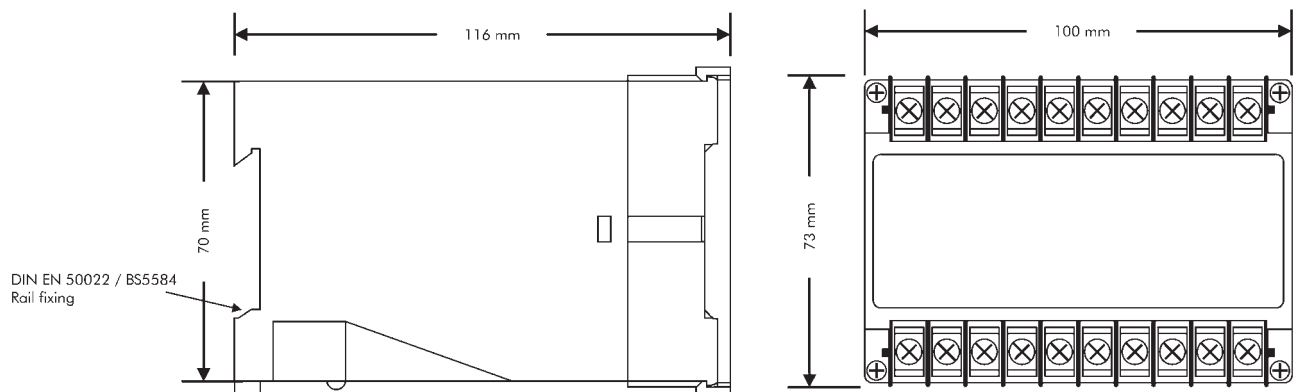

## ACTIVE ENERGY



The T25-WH are electronic transducers converting active energy in single or three phase balanced or unbalanced systems to simultaneously produce a digital pulse output for cumulative energy signal.

### Model

- T25-WH10** - single phase watt-hour transducer
- T25-WH12** - 3ph 3w bal. load watt-hour transducer
- T25-WH13** - 3ph 4w bal. load watt-hour transducer
- T25-WH20** - 3ph 3w unbalanced load watt-hour transducer
- T25-WH30** - 3ph 4w unbalanced load watt-hour transducer

### General Specifications

#### Test voltage

4kV AC rms 1min between terminal/case  
2kV AC rms 1min between  
input/output/auxillary according to IEC801-4

#### Impulse test

5kV, 1.2/50 $\mu$ s according to IEC 255-4

#### Noise test

2.5kV, 1MHz according to IEC 255-22-1

#### Radio Screening

RFI degree complies with VDE0875

#### Working condition

-5 °C to 60 °C, 20-99% RH  
non condensing

#### Storage condition

-20 °C to 70 °C, 20-99% RH  
non condensing

#### Humidity

JWE operation class according to  
DIN 40040

#### Stability

100 ppm / °C, <  $\pm$  0.2% drift per year, non  
cumulative

#### Magnetic effect

<0.05% change 1M centre 100AT,  
synchronized with line frequency

#### Aux power effect

<0.005% per volt change

### Technical Specifications

#### Input

##### Voltage

69V (3ph 4w), 120V, 240V or  
415V,  $\pm$  25%

##### Burden

0.2VA

##### permissible overload

1.25 X rated voltage continuous

##### Current

1A, 5A

##### Burden

0.3VA typically

##### permissible overload

2 X rated cotinuous,  
10 X rated - 10secs,  
25 X rated - 2 secs,  
50 X rated - 1 sec.

##### Frequency

50 or 60 Hz,  $\pm$  2hz

#### Output

##### Output rating (digital)

Open collector type - max.30V/30mA;  
reed relay type - max. 50V/40mA  
export pulse optional

##### Accuracy (23 $\pm$ 5 °C)

$\pm$  0.2% RO according to IEC 688-1

##### Ripple Factor

less than 0.5% p-p

##### Response time

<400ms

##### Output Adjustment

span & zero adjustments where applicable

### Auxillary Power Supply

#### Standard Range

110V, 220V  $\pm$  20% 50/60Hz, <4VA

#### Options

self power and other AC power supplies up to  
440V ac on request. DC powered models available  
at additional costs

### Physical Specifications

#### Dimensions

100W x 78H x 116D mm

#### Enclosure code

IP 50 (case)  
IP 30 (terminal)  
according to IEC 529/DIN40050

# Wiring Connections

## T25-WH

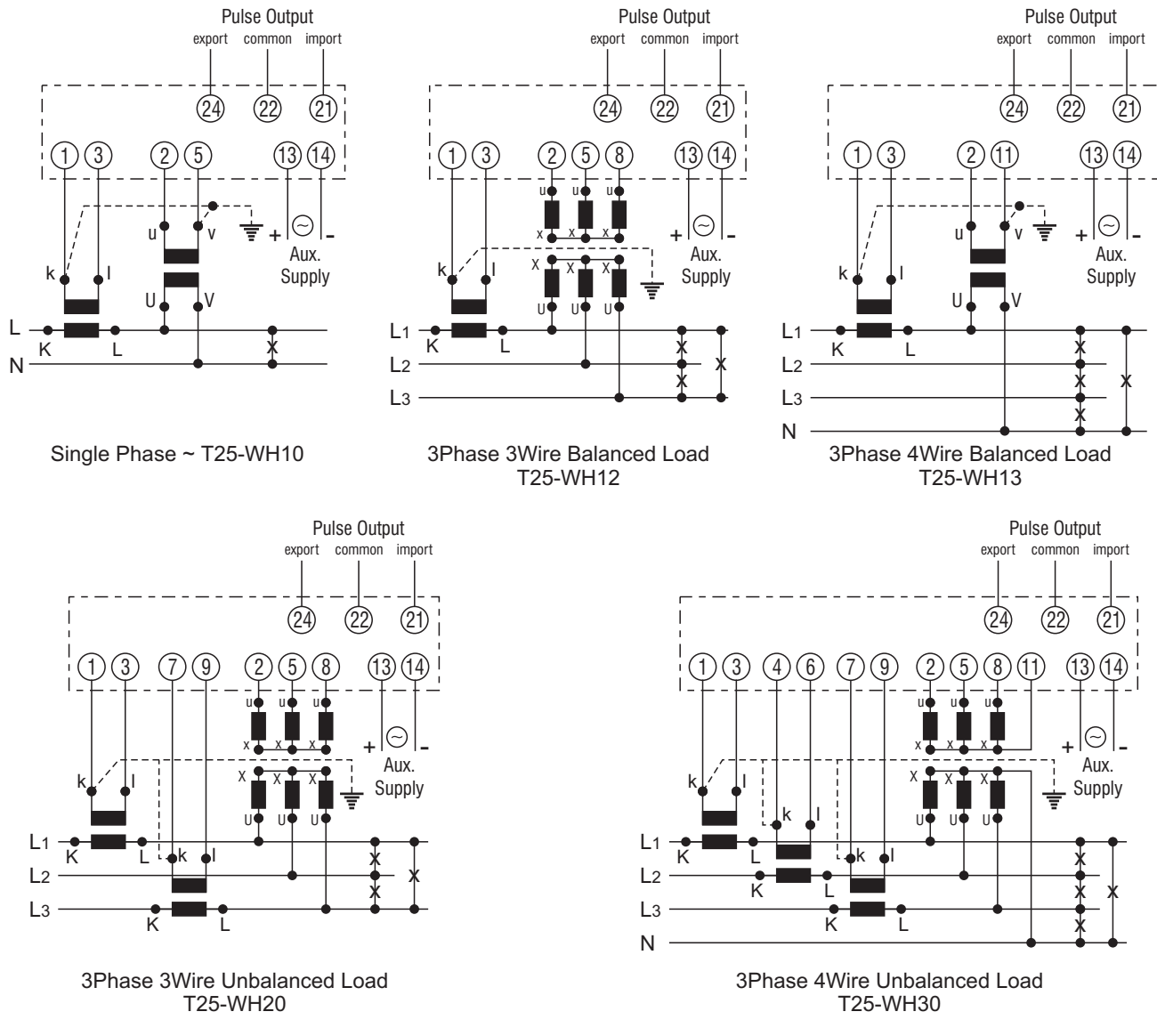

# Dimensional Drawings

